

**STANDARDS FOR THE DESIGN  
AND CONSTRUCTION OF  
ROADS  
IN THE LONDON BOROUGH OF LEWISHAM**

<b>CONTENTS</b>	<b>PAGES</b>
NOTES ON HIGHWAYS AGREEMENTS	2 – 20
DESIGN NOTES ON SECTION 37,38 AND 278 PROPOSALS	21 – 36
DESIGN OF PAVEMENTS	37 – 44
FOOTWAYS AND FOOTPATHS CONSTRUCTION	45 – 48
NOTES ON COMMENCEMENT OF WORKS	49
SPECIFICATION OF WORKMANSHIP & MATERIALS	50 – 76
REQUIREMENTS FOR ADOPTION OF HIGHWAY STRUCTURES	77 – 78
CONTACT DETAILS	79- 80
INDEX OF SPECIFICATION	81 – 82

Public Realm Directorate , Highways and Transport, Highways Group

Updated Version  
November 2020

### Road Adoption

Road adoption is a process where a road in private ownership becomes a public road, which is then managed and maintained by the Council, as part of the public highway if it is constructed to adoptable standards in terms of layout and construction.

The Council does not adopt all new roads built by housing developers. Housing developers can choose to keep their new roads private if roads do not meet the Council's criteria. We do not normally adopt existing private roads unless they are brought up to the Council's current standards by the owners of the road.

A new road will be considered by the Council for adoption provided that the freehold owner(s) of the land dedicate the road as a public highway, when it is built, under a Section 38 Agreement of the Highways Act 1980, and the following criteria are to be met:

- there is a direct link with the existing public highway network
- it must be of sufficient utility to the public and offer wider community benefits
- the roads offered for adoption will have a wider use than simply providing access to residential or commercial properties
- the road will remain open to the public to pass and re-pass at all times when formally adopted
- the carriageway and footways offer safe passage for pedestrians and vehicles
- the carriageway and footways have an approved means of surface water drainage
- street lighting must conform with current local and national standards in accordance with the Croydon & Lewisham Street Lighting Standard Development Specification
- the roads offered for adoption are designed and constructed to a satisfactory standard
- commuted sums are paid, where required, to provide ongoing maintenance for soft landscaping, non – standard materials, street art and seating
- a bond is entered into for 110% of the estimated road construction costs to guarantee the agreement or alternatively a deposit to this value is placed with the Council
- all fees, deposits, charges are paid
- the roads are maintained for a minimum of one year after the final phase has built and this completion has been certified by the Council's Engineer

For all roads offered for adoption, the developers to ensure that these will accord with the above criteria prior to consulting the Council. When considering whether to adopt a road, the Highway Authority considers whether it will have sufficient public utility and that the Council does not take on liabilities that it is not prepared for and which are not in the general public interest. To clarify:

- where developments have no through route, only the main access road will be considered for adoption subject to the main access road serving in excess of 50 residential units.
- bus routes as well as roads serving community facilities will be considered for adoption
- residential roads serving underground car parks, supported by structure or taking the form of cu de sacs with no wider highway benefit will not be considered for adoption.

A new road will be considered for adoption provided that it meets these design standards and the developer enters into a suitable legal agreement with the Council (Section 38 Agreement of the Highways Act 1980). For all new roads, developers must approach the Council's Highways Engineering Team about adoption.

Existing roads will not be considered for adoption unless they are of sufficient public utility and are brought up to the Council's standards by the owners of the road.

### Highways Act 1980 – Provisions for Legal Agreement

Section 38 of the Highways Act 1980, enables a local highway authority to enter into an Agreement with any person, (to be referred to in this document as "Developer"), who intends to construct a highway. Such an agreement may contain provisions requiring the Developer to construct or make up the highway(s) to the Council's requirements and specification. Upon satisfactory completion of the works, and expiration of a period of maintenance, the highways, which are subject to the Agreement, will become maintainable at the expense of the Council.

Adoption under Section 37 of the Highways Act 1980 is to be avoided wherever possible and Section 38 is the preferred method for adoption. Under Section 37, a developer can give notice to the authority that it intends to dedicate a road or street as a public Highway. If the authority considers that it will not be of sufficient utility to the public to justify it being maintained at the public expense or considers that it has not been properly constructed or maintained then the dispute will need to be decided in the magistrates' court.

Under the provisions of Section 278 of the Highways Act 1980, it is possible for a local highway authority to enter into an Agreement with a Developer or other person for the execution of highways works on existing highways at the developer's expense. Section 278 provides that if the highway authority is satisfied that it would be of benefit to the public it may enter into an agreement. Subject to approval, from the Council's Engineer, these works may only be executed by the Developer(s) Contractor where they will have a major effect on the developments construction. However, these works are often executed by the Council with payment for such works being made by the other party( s) to the agreement. Such works can be the requirement of an obligation secured by the Council as Planning Authority under Section 106 of the Town and Country Planning Act 1980. Upon satisfactory completion of the works, and expiration of a period of maintenance, the payment of all agreed costs arising to the Council, the Developer will be released from the planning obligation.

The Community Infrastructure Levy (CIL) is a levy that Lewisham has adopted which limits the works to be carried out through Section 106 powers.

Amenity areas, car parking areas, play spaces and other open spaces not necessary for highway purposes shall be excluded from a Section 38 Agreement, as these are areas the Council would not wish to adopt as highway.

The Council will impose conditions within the terms of any such Agreements relating to the type of construction, materials and standard of workmanship to be employed which would be acceptable to the Council for the purposes of future maintenance.

When a Developer wishes the Council to consider entering into a Section 38 and/or 278 Agreement, the request should be addressed to:-

Public Realm Directorate  
Highways and Transport  
Highways  
The London Borough of Lewisham  
Laurence House  
Catford Road  
4<sup>th</sup> Floor  
London SE4 4RU

### Design by Developer

The design of the works shall be the responsibility of the Developer who should have due regard to the advice in this document, the current Manual of Contract Documents for Highways Works – July 2019 Amendment Volume 1 Specification for Highway Works, Design Manual for Roads and Bridges, Transport Research Laboratory recommendations and reports, Lewisham Local Development Framework, Manual for Streets, Manual for Streets 2, London Cycle Network Design Manual, Croydon and Lewisham Street Lighting Standard Developers Specification and other reports and current practices of the Council. If in doubt as to the standard to be applied in any particular case the Developer is advised to consult the Highway Manager or the Engineering Manager at an early stage of the design.

The Developer is advised that time may be saved by informal discussions with the Development Officer at pre planning application stage, and in some instances the Engineer or representative, prior to the submission of detailed highway proposals. Its purpose is to bring together all highways and transportation, planning and any other relevant matters. Normally at this stage we will require the developer to present one or more plans along with any supporting information. Such discussions will also determine whether there is a requirement for works to the existing highway and whether there is sufficient utility within the development proposals to justify the street or streets becoming highways maintainable at the public expense.

The frontage footways and carriageways can often be damaged through new utilities connections, site operations, hoarding and scaffolding. As a result it is usual that the Council will require that the footway frontage and in many instances the carriageway to be repaved by the developer, under a S278 Agreement, or through a contribution to the Council at an estimated value to be approved by the Engineer. The extent of such works will be assessed for each site individually by the Engineer or his Representative.

Where new highway structures are proposed for adoption then informal discussions are also required with the Highways Manager and the Engineer.

The design details will be checked by the Engineer or a representative upon receipt of the written request for technical approval and an application fee for larger developments. In general, officers have delegated authority to consider applications for works to be carried out that are subject to agreements under Sections 38 and 278 of the Highways Act 1980. The Developer or other person will be informed of the acceptability of the submitted proposals accordingly

### Design Considerations

The Council accepts the general approach contained in the Department for Transport's Manual for Streets and the Manual for Streets 2 published by the Chartered Institution of Highways and Transport. However, it is stressed that any design presented will be considered on its merits, and if, in the opinion of the Engineer it is reasonable or necessary to waive or vary the standards contained in this document due to site specific requirements a recommendation will be made accordingly.

The boroughs existing road network is within 20mph limit and Zones which are generally enforced through traffic calming with features less than 70m spacing. New residential roads should be designed for speeds of 20mph or less. Provision for making any necessary traffic order and the cost of making them will be required in the highways agreement.

Car parking is a key function and many of the borough's existing roads are within Controlled Parking Zones (CPZ). Any new public highways that are within the boundaries of an existing or proposed zone will need to be incorporated in the CPZ. Parking details and schedules will need to be drafted and then agreed with the Principal Parking Engineer, whom will authorise the necessary traffic parking orders. Planning obligations for such developments may include a provision for making or amending a CPZ traffic order but in some instances this will be included in the highways Agreement.

The Council has a Street Lighting Private Finance Initiative (PFI) with Skanska for the replacement of its lighting stock and ongoing maintenance including that of illuminated signs. The replacement of the borough's lighting stock was completed in 2016. Upon request the Council can provide The Croydon & Lewisham Street Lighting Standard Developers Specification. This document has been prepared for developers proposing to install street lighting to adoptable standards within the scope of the PFI. The Developer must seek advice from the Street Lighting Client Monitoring Manager on its street lighting design at an early stage.

Structures supporting the Highway, in the form of bridges and/or walls, must be designed in accordance with the latest version of the Design Manual for Roads and Bridges. The design calculations, drawings, and specifications are to be undertaken and submitted under the supervision of a Chartered Civil or Structural Engineer together with a design certificate and design check certificate when appropriate. A full list of requirements is given in this document.

The application for Section,37,38,278 Technical Approval

The formal request should be in writing and accompanied by drawings submitted in Autocad 2020 (or latest version) with two hard copies illustrating:

- longitudinal and cross sections showing the proposed works relative to the existing ground conditions
- a setting out plan showing line, co-ordinates and levels
- a typical cross-section of the proposed highway construction drawings, specifications details and calculations relating to the road works. These should be provided as set out in the Series in the Specification for Highway Works
- location of sewers, service ducts, manholes, road gullies, sightlines, street lighting columns, street name places, traffic signs, road markings, soft landscaping should be shown
- swept paths for various vehicles including a 11.2m rigid vehicle
- location of existing and proposed utilities
- details of proposed highway structures in accordance with “Requirements for Adoption of Highway Structures” detailed at the end of this document
- construction traffic management plan for the development and the highway works
- details of traffic restrictions and traffic order schedules to enable traffic orders to be made
- proposals to remove any contaminated material that is anticipated in the existing and proposed highway
- construction phase plan as required through the Construction Design and Management Regulations 2015
- an initial programme for the works and adoption
- street lighting design to be submitted to the Street Lighting Client Monitoring Manager.

The submission should be accompanied by a soils report, which shall include:

- Soil classification
- Californian Bearing Ratio and/or other recommended ground bearing capacities for structures supporting the Highway where appropriate
- moisture content and sulphate content values.
- Nature and significance of ground contamination.
- Cores and/or trial holes through the existing carriageway, where any works are proposed, showing structure of road and evidence of any tar. Positions of cores/trial holes through the existing highway to be agreed with the Engineer prior to works commencement.

Footways	- Yellow
Carriageway	- Grey
Planted Areas	- Green
Gully Connection /Highway Drain	- Broken Blue Line
Site Boundary	- Blue Edging

In general, the highway plan will be based on the site layout of the development, which must previously have received Planning Consent.



Where the Council accepts the application, the Developer will be asked to supply details of:

- their legal representative
- an updated site programme
- contractors details
- proposed construction vehicle routes to and from the site
- maintenance schedules
- surety details
- public liability insurance and
- an estimate of the adoption construction costs.
- an application fee of £5,000 where the highways construction works is estimated at over £150,000 and this to be reimbursable where the Final Certificate is issued within 3 years of the initial application.

The Senior Planning Lawyer will communicate with the developer's legal representative with regard to the preparation of the formal Agreement. The Developer will need to supply proof that the Developer has ownership rights for the highways offered for adoption and deeds (where required) of easements from 3<sup>rd</sup> parties for highway drainage, consents and licenses or permissions as may be required to carry out any of the road works.

Where requested haul routes for heavy goods construction vehicles to be agreed with the Development Officer prior to any works commencing on site. Such details will include routes in the borough, type of vehicle, predicted travel times and volumes of traffic.

On entering into a highways agreement the Developer will need to provide the Council's Engineer with details of the main contractor and/or subcontractor(s) which will carry out the highway works and other such details include (not exhaustive); site contact details, method statements and a detailed programme for the road works.

Section 38 Agreements are often entered into alongside Section 278 Agreements, which allow the developer to carry out works to the public highway.

When the developer enters into either a Section 278 and/or Section 38 Agreement, they will be required to indemnify the Council against any claims arising from the works.

Street naming and numbering (SNN) will need to be carried out in liaison with Property Systems at [snn5690@lewisham.gov.uk](mailto:snn5690@lewisham.gov.uk). The SNN is a rechargeable service and the online street naming and numbering link is as follows :  
<https://www.lewisham.gov.uk/myservices/planning/street-naming/Pages/Street-naming-and-numbering-legislation.aspx>

Where it is necessary to place hoardings on the highway, or scaffolding, permission is required from the Council. Once approved a scaffolding or hoarding licence is required before commencement of works. There is charge for this service and a refundable deposit charge against damage to the public highway. The link to the Council's web page is as follows: <https://www.lewisham.gov.uk/myservices/business/licences-and-street-trading/building-and-construction/licences/Pages/Scaffolding-and-hoarding.aspx>.

It should be noted that where a legal agreement is required to be entered into for a Section 278 and or Section 38 then the hoarding licence cannot be granted until after this legal agreement has been entered into along with those fees paid at its engrossment.

### Commencement of Site Works

When the detailed design is agreed it will be necessary for the Developer to submit the plans electronically along with four complete sets of plans printed, all coloured as previously described, to the Engineer. Two copies of the coloured adoption layout drawings will then be sent by the Engineer to the Senior Planning Lawyer for inclusion in the Agreement. Highway works must **not** commence until Technical Approval has been given, an Agreement is signed and the Bond/Deposit is in place.

Work shall **not** commence on highway works until the Developer has paid all the payment obligations in the Agreement including; adoption and legal fees, traffic orders and costs, commuted sums and minor works deposit to the Council.

Condition of the existing highway, including photographs, at the development address to be submitted and agreed with the Engineer's representative prior to works commencing on site. Any cores or excavation for site investigation to the existing public highway will require permits as detailed in this document.

All traffic safety and management measures necessitated by the works shall fully conform with the requirements of the New Roads and Street Works Act 1991, as amended, and shall have been approved by the Network Co-ordinator before the Developer commences any work which affects the public highway or use of it.

If construction work has not commenced within 2 years of the date of the Agreement, the Agreement shall cease to have effect.

### Drainage Approval

Section 104 of the Water Industries Act 1991 provides for a 'sewerage undertaker' (Thames Water) to take over, by agreement, ownership and maintenance of any 'sewer or sewer disposal works'.

All highway water should be drained directly into a piped system adopted by Thames Water. All highway drains should be located within land that is to become public highway or is to be adopted. The Council does **not** wish to adopt extensive highway drains and linear slot drainage systems. The highway drainage required for adoption is to be minimised to that of gullies and their connections to Thames Water sewers. The Council does not adopt a road unless its associated drainage is to be adopted either by Thames Water or the Council. The Council does not accept drainage of other non-adopted areas discharging onto and into any highway drains. The Council considers alternative highway-drainage systems, including SUDS, flow attenuation or retention systems and so on, on a site-by-site basis.

### Road Safety Audits

Proposals will normally require a detailed design stage Road Safety Audits (RSA) to be submitted. The RSA should include an assessment of the relative significance of any potential safety problems. For S38 works Stage 2 and 3 audits will be required and for S278 works Stage 1, 2 & 3 audits are required. The Engineer can request a Stage 4 audit before issue of the final certificate.

In some instances separate Cycle Audits will be requested by the Engineer.

### Performance Bond

On completing a highways agreement the Developer will also be required to provide a performance bond equal to 110% of the estimated value of the works. The estimate should include for any statutory utility works that are required as part of the highway works i.e. diversions of mains. Evidence will need to be provided of the estimate provided by the Developer. The estimate will be checked by the Engineer who will decide the final value to be included in the highways agreement. The bond will enable the works to be completed in the event of default by the Developer. In the event that there is a change such that the performance bond cost no longer reflects the amount reasonably required to carry out the works, then an additional bond will be required for the increased value. The increased value to be a sum as determined by the Engineer, acting reasonably. A cash deposit equivalent to the estimated cost can be paid in lieu of the bond. The bond value can be reduced in line with the Agreement "Certificates" as issued by the Engineer.

### Certificates, Maintenance Period and Adoption by the Council

The Developer to notify the Council's Engineer when any part of the highway works are complete in accordance with the Agreement. The Engineer can issue an Interim, Provisional and Final Certificates when satisfied that the works have been completed under the provisions of the Agreement. In smaller developments and for Section 278 works the certification shall be "Initial" at the works completion and "Final" after the maintenance period has been completed. All payments required under the Agreement need to have been made before the issue of any certificates.

In larger developments the certification can be staged but the final certificate cannot be issued until the last phase of the development is complete. Interim, Provisional and Final Certificates are that usually certified for such larger developments where the highway works value is above £500,000. Upon issue of an Interim Certificate occupation or trading can be permitted for any building or part of a building as part of the Development or development phase. The Developer is required by the terms of the Section 38 Agreement to provide a completed access using footpaths or footways and the carriageway constructed to at least binder course level along with road lighting from an adopted public highway up to the frontage of any completed property prior to any issue of the Interim Certificate by the Engineer.

The Developer will need to inform the Council when the scheme is complete and ready to be inspected. Once the scheme is substantially complete an inspection will be required before the Council can issue a Provisional/Initial Certificate under the provisions of the Agreement. This Certificate can only be issued after the highway works have been completed to Council's satisfaction and this includes the requirement for a completed Stage 3 Road Safety Audit and any resulting alterations have been made. Issuing the Provisional/Initial Certificate marks the beginning of a period (usually 12 months) where the Developer is responsible for maintaining the works. A snagging list with dates for completion along with a "maintenance schedule" to be agreed with the Engineer before the maintenance period commences. After issue of the Provisional/Initial Certificate the bond can be reduced, normally to 10% of its original value.

It should be noted that a Stage 4 Road Safety Audit may be required, where requested by the Engineer. The Final Certificate can only be provided after this audit has been completed along with the Developer rectifying any potential hazards identified in the audit and/or by the Engineer. In addition, prior to the issue of this certificate, the Developer needs to provide all highway as built drawings electronically and the relevant Health and Safety File. Once the Final Certificate is issued, the Council becomes responsible for maintaining the works at the public expense and the bond can be released.

The Council specifies a 12 months "maintenance period" or longer on highway works. Longer periods will be required where the proposals require a Stage 4 Audit or the scheme does not conform to the Council's standards for construction. On roads to be adopted the maintenance includes for general highway maintenance as well as construction defects. The inspection and general maintenance to follow Lewisham's "Well managed Highways Infrastructure Code of Good Practice", 2018, which can be made available upon request. The developer to note that on residential roads a detailed inspection is generally required twice a year during the maintenance period.

Fees, Payments, Commuted Sums, CAVAT, Deposits, Traffic Order Costs and other Charges

A charge equal to 8% of the estimated value of the road works will be made by the Council in order to cover its technical, administrative and site supervision costs. The road works estimate to include statutory utilities costs associated with the highway works. Where the highway works are estimated by the Engineer, at over £150,000 then the formal request should be accompanied by a reimbursable application fee of £5,000. This application fee is only reimbursable after the issue of the Final Certificate. Developers will also be required to pay the Council's legal fees for drafting and negotiating the terms of the Agreement plus any disbursements (money we pay on your behalf). This fee is set by the Head of Law and is reviewed annually.

The Council's Private Finance Initiative standards include for "Installation Acceptance Costs" for inspection of apparatus installed by the developer. Please refer to Croydon & Lewisham Street Lighting Standard Development Specification June 2020 version, which is also available upon request from the Street Lighting Client Monitoring Manager.

Should the Developer wish to make revisions to the design or programme after the technical approval and the signing of the Agreement, then this will need to be sought from the Council's Engineer. A Deed of Variation on the Agreement will result in additional fees for any of the Council's legal, technical and site supervision costs.

If the highway works are still not complete after the time limit specified in the Agreement, the Council can offer an extension of up to twelve-months, but the bond value will need to be re-assessed. There will be a charge for further inspection fees based on our assessment of the cost of the outstanding works, with this fee set at a minimum charge of £1,000.

S38(6) provides the power to seek commuted sum for the construction, maintenance or improvement of any road or way to which a highways agreement relates. Where Section 38 works are deemed as “standard construction”, commuted sums are not generally considered appropriate.

Commuted sums will be sought and this will be for any; special features (eg street art), seating, soft landscaping, highway structures, alternative “non standard ” materials eg proprietary surfacing, granite paving and setts, yorkstone paving, resin bonded surfacing, Breedon gravel or such similar surfacing, extensive highway drainage including linear drainage, SUDS and additional areas not required for normal highway purposes. Commuted sums are generally required for “extra over” costs to be met by the highway authority and these include that for special features. Where there are works to the existing highway network and such “non standard” materials are required to match the existing then no commuted sum for these element of the works will generally be sought. Please refer to the guidance document “Commuted Sums for Maintaining Infrastructure Assets” by ADEPT( formerly County Surveyors Society) , to calculate the sum. “Non-standard” is defined as all construction types or materials that are not included in the definition of ‘standard’ construction within this specification.

The costs represent the increase in the Council’s future maintenance liability and is the difference in costs between the assets provided and the “standard” that will be subject to future maintenance. The commuted sums represent the most typical values that Highway Authorities apply over a 30 year calculation period based on that adopted in the guidance document.

The Council normally does not generally adopt planted landscaping areas, grassed areas, trees, and shrubs. Where adopted the Council specifies a five year maintenance period within the highways agreement to enable the street planting to be established. Alternatively a commuted sum for future maintenance can be made payable to the Council and the sum will be determined by the Engineer.

Valuing amenity trees is important for calculating loss of amenity and for the tree replacement value, following any willful or negligent damage. Capital Asset Value for Amenity Trees (CAVAT) is a tool for valuing amenity trees. This is the required monetary value to be paid to the Council for loss or damage of highway trees. The base value of a tree is calculated using the Equation  $BV = \pi r^2 \times UVF(1)$  where r is the tree radius in centimeters and UVF is £15.88. Please refer to “CAVAT: Capital Asset Value for Amenity Trees: valuing amenity trees as public assets”.  
<https://www.tandfonline.com/doi/full/10.1080/03071375.2018.1454077>

A minor works deposit will be required by the Council to secure the performance of Developers in respect of; any public highway traffic management, ensuring that the existing highway is kept cleared of mud and any other detritus, making good any damage to the highway caused by the development site. The deposit value required will normally be a minimum of £5,000 and up to £10,000 for schemes estimated as below £150,000. For highway schemes of a value above £150,000 and/or the development is to be on site for more than one year then the deposit required will be £25,000. These deposits will be included in the Agreement.

Works to (or affecting) the existing highway may require an order made pursuant to section 14 of the Road Traffic Regulation Act 1984 to restrict or prohibit temporarily the use of any road in order that the highways works to sites abutting the highway can be carried out safely and expeditiously. A fee is payable to the Council for costs, a minimum of £2,000 or, as specified by the Engineer for making any Temporary Closure Orders.

Where (permanent) traffic orders are required then the costs will be specified by the Engineer and the minimum cost will be £5,000, except for individual car club bays where the minimum cost of £4,000 will be considered. Such examples of traffic orders will be for; waiting and loading restrictions, parking bays, floating car club bays, loading bays, controlled parking zones, 20mph speed limits/zones, weight restrictions, one-way streets, pedestrianised streets, HGV restrictions.

Any overdue sums payable in the Agreement will accrue interest at 2% above the bank base lending rate. This to be calculated from the date of the signed Agreement or development works have started on site, whichever is the sooner.

Should any of the fees, charges and commuted sums **not** be paid then the Council will not adopt the road(s) nor allow permits to be issued to allow works on the highway.

Permits and Licenses

The fees for permits were reviewed in 2019 and the charges in the document represent the fees proposed from 2020.

Permit fees for Scaffold licence – £280 for a 3 month deposit plus £60 inspection fee and a refundable deposit charge against damage to the public highway. There will be a £500 penalty fee if a site is found to be without a valid licence.

Permit fees for Hoarding licence – £195 for a 3 month deposit plus £60 inspection fee and a refundable deposit charge against damage to the public highway.

Additional application for a Scaffold and Hoarding permit is £60 for up to each 3 month period.

Contact for Hoarding and Scaffold Licences is 020 8314 6565 or apply on line.



The London Permit Scheme for Road Works and Street Works (LoPS) imposes duties and policies on the Council to manage works and other activities in the street so as to minimise the impact of those activities, while allowing essential work to take place. Lewisham Council is a permitting authority operating LoPS to assist in meeting its network management duty. Permits to work in the Highway are required for any Registerable activity and include all works that involve:-

- The breaking up or resurfacing any street;
- The opening the carriageway or cycleway of any traffic sensitive streets at traffic sensitive times;
- Any works requiring any form of temporary traffic control;
- The reduction in the number of traffic lanes;
- Temporary traffic orders or notices, or suspension of pedestrian crossing facilities;
- The reduction of carriageway width of any traffic sensitive streets at traffic sensitive times;
- Pole testing involving any excavation or reinstatement;
- Street lighting.

A LoPS requirement is required for non-excavation works where this includes temporary traffic management works on the highway.

Provisional Advance Authorisations ( PAA's) must be sought for major works and costs £105 or £75 dependant on whether the road is deemed traffic sensitive or not.

The LoPS requires promoters to apply for both a Provisional Advance Authorisation at least three months in advance of the activity and a Major Works Permit one month before any planned activity of over ten days duration is due to start. A Standard Works Permit is required for works between three days and ten days duration and a Minor Works Permit for work durations up to three days. For Standard Works the promoter to apply for a permit 10 days minimum in advance of the works and 3 days minimum for Minor Works.

Permit fees also apply for variations to granted per permits. See table below for fees.

Category 0,1, 2 and Traffic Sensitive Roads					
PAA	Major	Standard	Minor	Immediate	Variation
£105	£229	£130	£65	£47	£45

Category 3, 4 and Non Traffic Sensitive Roads					
PAA	Major	Standard	Minor	Immediate	Variation
£75	£150	£75	£42	£30	£35

Permit applications can be made through the Streetwork Permitting. Please contact [Streetworks@lewisham.gov.uk](mailto:Streetworks@lewisham.gov.uk). Full details of the scheme can be found on [www.londoncouncils.gov.uk](http://www.londoncouncils.gov.uk).

Contractors may be required to apply for a street works licence under section 50 (s50) license of the News Roads and Street Works Act 1991(NRSWA), in order to work on the public highway. This is a system whereby the Highway Authority can ensure the suitability of contractors carrying out works on their highways. An approved s50 license will, in such circumstances, be a condition of granting approval for a permit under the LoPS, however this will involve additional fees. The fees for a s50 licence are £440 for new apparatus and £270 for works on any existing apparatus, in addition there will be a refundable deposit which will be based upon the extent of the works.

To minimise damage to the structure of the existing public highway the Developer will need to consider whether there are any current restrictions under Section 58 and 58a of the NRSWA. If necessary the Council may issue a notice pursuant to those sections in respect of new works and a fee element to cover this function will be recovered from the Developer. Liaison should be through the Network Co-ordinator.

Summary Table of Highways Scale of Charges (excluding legal fees) from April 2020

<b>Description</b>	<b>Unit</b>	<b>Fee/Charge</b>
Domestic Crossover Application	Each	110.00
Domestic Crossover Installation	Each	1000.00
Domestic Crossover Extension	Each	300.00
CPZ amendments due to crossovers	Each	250.00
Access Bars (road markings)	Each	75.00
Inspection of re-chargeable works and other fees	Hr	75.00
Skip Licence	Per Month	65.00
Container Licence	Per Month	110.00
Scaffold Licence	3 months	280.00
Scaffold Licence renewal	3 months	60.00
Hoarding Licence	3 months	195.00
Hoarding Licence renewal	3 months	60.00
Materials licence	3 months	65.00
Emergency Temporary Traffic Order	Each	400.00
Temporary Traffic Order	Each	2000.00
Highway Searches	Each	75.00
Crane Licence and over-sail	3 months	405.00
Crane Licence and over-sail extension	1 month	110.00
Section 50 Licence new apparatus	Section 50	440.00
Section 50 Licence existing apparatus	Section 50	270.00
Traffic order for permanent restrictions or changes	Each	5000.00
Car club bay individual order	Each	4000.00
Notices for road humps and controlled crossings	Each	3500.00
Section 38 Road Adoption Agreement	8%	8 Percent
Section 278 Works on highway by outside body	8%	8 Percent
Application fee for S38/S278 Agreements where over £100k of works	Each	5000.00
Commutated Sums for non-standard highway works	Each	ADEPT Calculation formula
Stopping up and diversion orders of the highway (Town & Country Planning Act section 247 and section 253)	Each	5000.00

Fixed Penalty Charge Notices for breach of licences £100 but reduced to £0 if paid within 14 days as set by London Councils.

Traffic Signals

Where new traffic signals or modification to existing signals are required then approval is required from the Transport for London (TfL), Principal Sponsor, Surface Strategy and Network Development, Better Routes & Places, Surface Transport. The TfL contacts are listed in the contacts details of this document. Ad hoc advice for pre-feasibility work is limited prior to scheme submission and the contact at TfL is through [Section278Team@tfl.gov.uk](mailto:Section278Team@tfl.gov.uk) and TI- Signals, Traffic Operations, Surface Transport. Such design should be undertaken by Engineers with an expert knowledge of TfL's specification and practices. New signals will need to meet with TfL's justification criteria and modelling evidence will need to be provided. TfL require payment of a design cost of £5,000 per site to carry out an assessment and for including the scheme proposal onto their programme slot . An Autocad drawing scale 1:200 is required as part of any scheme submission document. TfL to be contacted with regard to their latest requirements.

TfL's sum for commuted maintenance and installation is based on what is installed along with a modernisation sum after 15 years. The criteria is based on a 30 year maintenance period taking into account the Net Present Value (NPV).

Commuted Maintenance Summary:

- Energy (*per year*)
- Telecom Line Rental (*per year*)
- Equipment Maintenance (*per year*)
- Maintenance Staff (*per year*)
- Supplementary Works (*per year*)
- Site Modernisation (*per modernisation*)
- Base Civils Cost (*per site*)
- Civils Cost (*per pole*)
- 50% of Civils Cost

**Commuted Maintenance** = Total commuted maintenance cost (NPV)

For guidance TfL have an average cost for “small”, “medium” and “large” signal projects exclusive of commuted maintenance and any civils costs, which are shown below( 2015 figures) and updated costs needs to be ascertained from TfL:

Size of Scheme	Average Cost
Small	£7,500
Medium	£23,500
Large	£ 55,750

TfL require the borough to submit the proposals and make the payments and this needs to be made prior to the highways agreement being completed. Scheme submissions to Traffic Infrastructure Engineers; [TISchemeSubmission@tfl.gov.uk](mailto:TISchemeSubmission@tfl.gov.uk). Lead in period for booking signal site works to be on site with TfL can vary and this to be ascertained from TfL. The Developer will need to contact TfL to ascertain up to date costs for design assessments, installation and commuted maintenance for each site. TfL's contact details for the borough is included in the “Contact Details” of this document.

Traditional Carriageway and Footway Widths

The required “minimum” widths of carriageway and footways for streets in residential areas are as follows:-

<u>Residential Roads</u>		
<u>Means of Access</u>	<u>Carriageway Width Minimum</u>	<u>Footway Widths Minimum (on each side)</u>
Principal road (with parallel kerbside parking in the carriageway on one side or on alternate sides).	6.0m	1,8 m
Principal road with parking bays adjacent to running lanes.	5.5 m (excluding parking bays)	1.8 m
Secondary road with parking bays adjacent to running lanes.	5 m (excluding parking bays)	1.8 m
One way streets (with parking restrictions)	3.7 m	1.8m
Secondary access (with parking restrictions)	4.1 m	0.6 m
Where footways incorporate trees		2.4m

The Council has introduced a 20mph borough wide speed limit, thus the recommended design speed for residential streets is 20mph.

The above minimum standards are applicable to residential streets for the majority of developments. If however, the development is of sufficiently high density or the possibility of future extension exists or if it is considered that through traffic or extra parking may be attracted then it may be necessary to provide a carriageway width in excess of the above and footway widths compatible with the size of the development.

Cul-de-sac not to exceed 185m in length and where longer than 20m, a turning area is required.

The above carriageway widths to be a minimum of 5.5m if the length is to be traversed by buses, servicing vehicles and/or refuse vehicles.

In lightly trafficked streets the carriageway may be narrowed to a single lane as a traffic calming feature.

On secondary means of access one footway should be a minimum of 1.8m wide where more than a minimal flow of pedestrian traffic is envisaged.

Where pedestrian routes are provided remote from the carriageway then verges of 0.6m wide will be provided to accommodate vehicular overhang and occasional pedestrian movement.

### Kerb Radii

For residential roads and principal means of access the kerb radius at junctions will normally be 6 metres or approved compound kerb radii. Dropped kerbed pedestrian crossings with tactiles are required at junctions. At junctions where corner radii is less than 6m then the footway shall be strengthened with 150mm sub base combined with 80mm thick blocks laid in herringbone pattern on 50mm thick sand bed.

### Junctions

The majority of junction arrangements take the form of a priority junction where the footways can be constructed with grey blocks in the quadrant formed by the radii. T types staggered or crossroads are normally appropriate where traffic flows to and from minor roads are relatively light. Where flows are heavier or layouts are complex then other types of control are required. Junction alterations require the developer to enter into a Section 278 Agreement.

Junctions involving Strategic Routes or traffic signals will require Transport for London Approval.

In general junctions with London Distributor Routes shall be in accordance with the Design Manual for Roads and Bridges Volume 2.

Some junctions may require entry treatments in accordance with the Council highway details ( available upon request from the Engineering Manager).

It is recommended that early stage discussion regarding the junction type, design and location should be held with the Engineer.

### Dropped Kerbs/Crossovers

Ramped 'Dropped Kerb' vehicular crossings should be used in lieu of kerb radii and quadrants. Individual garage access should, where possible, be dualled and ramps shall not be steeper than a gradient of 1 in 10.

On private driveways gradients may be increased to 1 in 8 on sites where level differences make it impractical to use less steep gradients. To avoid vehicles grounding on private drives the gradient should be maintained at 1 in 10 for at least 1.5m from the back of footway or include a vehicle roll over between the gradients.

Crossovers widths up to a maximum of 4.5m. Where an access has a total width exceeding 4.1m and serves a multiple parking area, then kerb radii is preferred.

Dropper kerbs shall be of minimum length 900mm, unless otherwise agreed with the Engineer.

A crossover fee of £110 and an application is required for that served of the public highway and can be found on: <https://lewisham.gov.uk/myservices/parking/crossovers--dropped-kerbs-and-whitelines>

Forward Visibility and Sight Lines

The vertical and horizontal alignment of carriageways should be such that a forward visibility is maintained commensurate with likely vehicular speeds. The 'minimum' acceptable forward visibility is 25 m SSD (stopping sight distance for 20mph) and 43 m SSD (stopping sight distance for 30mph). There will be situations where traffic speed can be controlled by reducing forward visibility. The forward visibility splay envelope along the road edge at radii will be dependent upon traffic and pedestrian volumes. Ideally parking should be omitted from the forward visibility splay.

Changes in alignment of the carriageway will be designed to maintain an acceptable forward visibility.

Where the forward visibility line crosses an area behind the highway boundary, it will be necessary to ensure that this area remains clear and unobstructed from a height of 0.6 metres above back of footway level. This requirement will not affect established trees where the foliage is above 3 m high.

For all road types within a development, visibility (at junctions, bends or crests) in the vertical plane should normally be measured from a drivers eye-height of no less than 1.05m above the road surface to a point no less than 0.6m above the road surface.

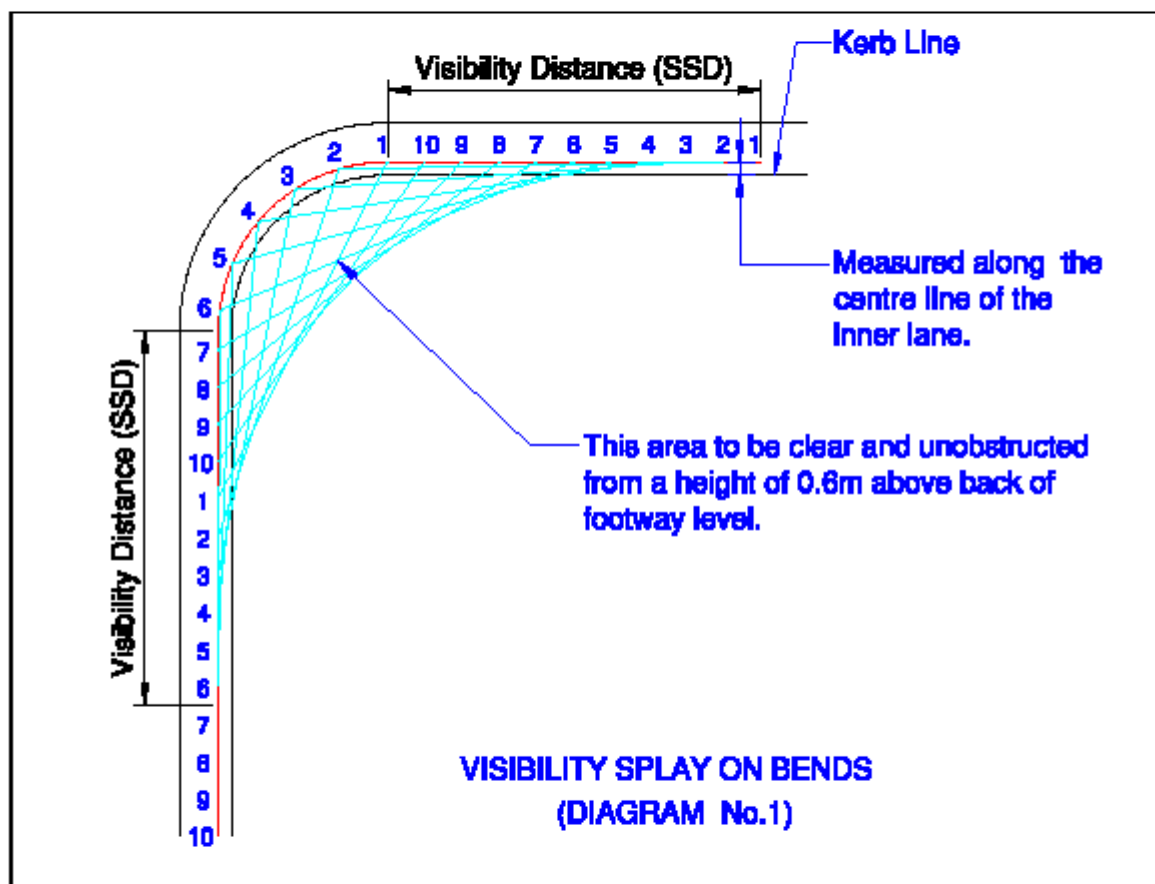

Parking bays should not be located within forward visibility lines and in visibility splays. The impact of street furniture on visibility should be assessed as part of the Road Safety Audits.

Sight lines in accordance with these standards should be provided for all new vehicle accesses. Where existing accesses are utilised or their use intensified, every effort should be made to secure the best sight lines while being sympathetic to the visual appearance of the street.

#### Visibility Splay and the Production of Adequate Sight Line at Junctions and Bends

Suitable splays are to be provided at road junctions. A minimum splay will be produced by a straight line between the points of intersection of the back line of path with lines joining that tangent points and the centre of radius, as indicated in diagram 2.

- (i) A line 'x' m long is measured along the centre line of the side road back from the continuation of the nearer edge of the major road carriageway.
- (ii) A line 'y' m long is measured along the nearer edge of the major road carriageway from its intersection with the centre line of the side road.
- (iii) The sight line is obtained by producing a straight line joining the ends of the above lines. In certain circumstances where the sight line to the left is difficult to obtain it may be permissible for the 'y' distance to be measured along the centre line of the major road carriageway.
- (iv) Where the junction is on a bend in the major road the whole of the major road carriageway is to be visible to drivers in the side road within the bounds of the 'x' and 'y' distances. This may involve moving the 'y' line back so that it meets the major road kerb line tangentially.

Type of Road	Design Speed/ Speed Limit	'x' m Desirable	'x' m Minimum	y' m minimum
District Road of Traffic Importance (TLRN - Westhorne Avenue only)	40 mph	8	4	80
Residential and District Roads	*30 mph	2.4	2.4	43
Residential Roads	20 mph	2.4	2	25

\*30 or 40mph design speed limit where requested by Engineer or onto TfL's road network (Westhorne Avenue A205– 40mph).



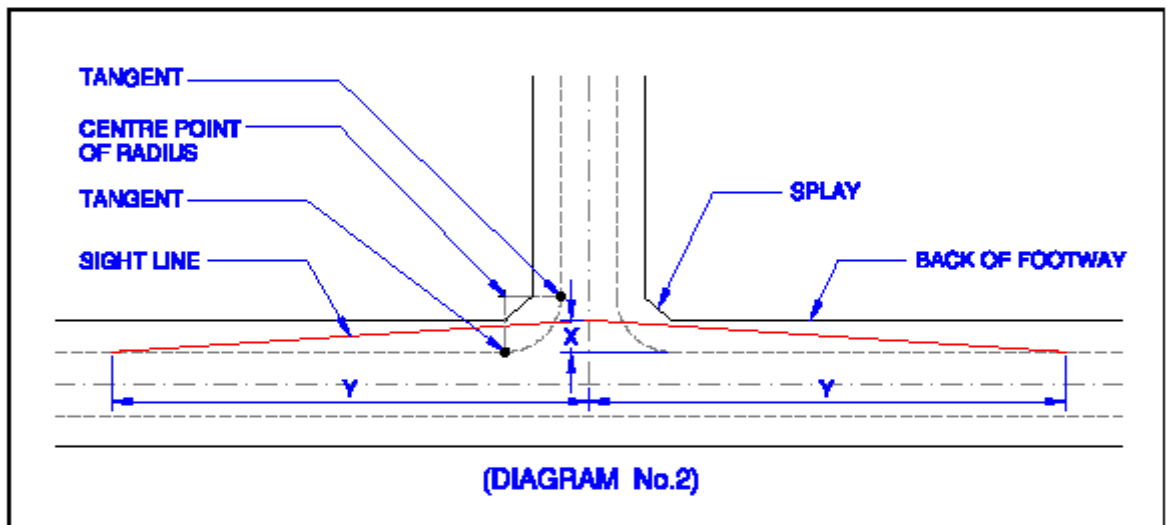

### Turning Facilities

Road layouts should, where possible, be designed to eliminate the need for drivers to make 3 point turns.

The minimum dimensions of turning facilities at the end of cul-de-sac in residential roads are shown on Diagram 3. Vehicle swept paths for 11.2m length large refuse vehicle will need to be demonstrated.

Motorists tend to park in areas designed to accommodate turning vehicles and it is good practice to extend the arms of the turning heads by 5m to accommodate this.

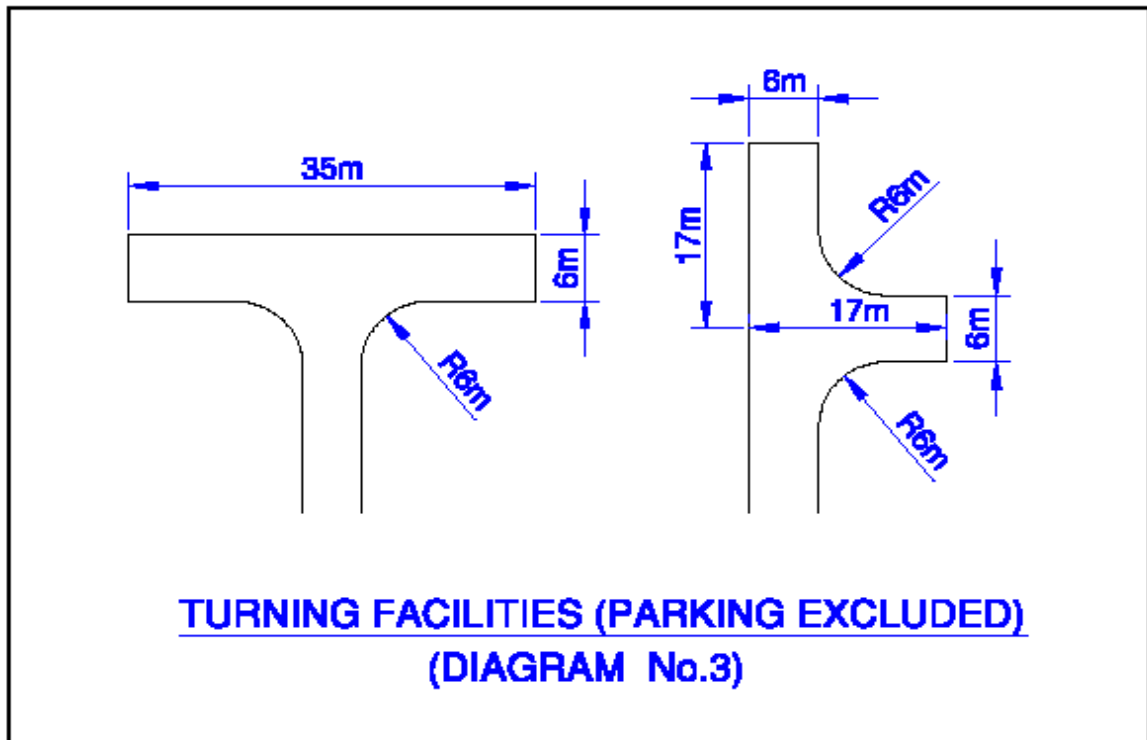

### Refuse Collection

Routeing for refuse vehicles should be considered at concept design stage and where possible designed to eliminate the need for reversing. Roads for refuse collection should have a minimum width of 5m and any pinch points 3.7m. Clear minimum height of 4.5m for any overhead fixtures.

The maximum haul for bins is 10m from the collection point to the kerb line.

### Parking Provision

The developer to make reference to the most recent Lewisham Borough Parking Policy which is proposed to be updated in 2020. On and off street parking provision should meet the standards set in the Council's Local Development Framework.

The location of car parking areas in a development should be considered at an early stage in the design process to achieve a balanced distribution of spaces throughout the site and be conveniently related for residents. Pedestrian access routes to parking should be designed so that it is easier and more convenient to use the designated parking areas than to park casually on the road.

Special consideration to be given to the needs of disabled people. It should be noted that generally the Council does not allow disabled parking provision on the existing public highway network for new developments. To date disabled bays in the borough are generally not enforced through a traffic order, although there are long term proposal for this to change.

Parking spaces, where provided, should be 2.4m x 4.8m for parallel and perpendicular parking with a 6m clear carriageway manoeuvring space. Reference to be made to Manual for Streets 2007 for parking layout design. Longer bays will be required in certain situations and bays provided for the ambulant disabled and wheelchair users should be 3.3m wide. Partial and footway parking should not be designed into new roads.

Where there is a need to regulate parking then this should be done by making appropriate traffic order regulations.

### Traffic Calming

The Council has a policy of a borough wide 20mph limit and as a consequence all new roads should be designed for this limit. Where there are valid reasons why vehicle speeds cannot be controlled through site layout then traffic calming measures may be used to achieve this but such consideration should be given to horizontal measures first and vertical measures second.

Where traffic calming is proposed then the Developer will need to consult the emergency services at an early stage.

Lewisham uses sinusoidal humps, height 75mm+/-5mm with length of 3.7m. Usual spacing of 70m with a maximum of 100m.

Raised junctions/Flat topped tables/Entry treatments may be appropriate for traffic calming at junctions, informal crossings or along routes. Along bus and emergency services routes a 6m plateau is required with 1 in 20 ramps with a maximum height of 75mm+/-5mm. These can be formed of asphalt, but where block pavers or mixture of both is used then granite kerb restraints are required on the top of the ramp. Tactile paving to be installed where footway level is at grade.

Flat top and junction entry treatments require a plateau length of a minimum of 2.5m and sinusoidal ramps.

Speed cushions are usually only installed on emergency service and bus routes. In Lewisham a height 75mm+/-5mm with nominal length of 2.5m and width of 2m (for bus route 1.6m to 1.7m is preferred). Maximum spacing for cushions of 70m.

Where any form of vertical calming feature is proposed, it should not be sited within 25m of the edge of a structure, for example, a bridge or culvert. They should also be sited clear of private accesses and driveways to avoid problems of vehicles 'grounding'.

### Signing and Reducing Clutter

Designers should begin by assuming a total absence of signs and only introduce them if they serve a clear function. There may be situations where there is an opportunity to reduce the existing sign clutter.

The Traffic Signs Regulations and General Directions 2016 (TSRGD) details traffic sign and road marking prescribed for use in the UK. Compliance with TSRGD is mandatory.

The impact of street clutter to be minimised by mounting signs on columns, consideration of streetlights onto buildings, bin stores off the footway, specifying orientation of inspection covers in footways. Mounting signs on existing columns will require approval from Skanska – please refer to “Contact Details” of this document.

### Shared Surfaces

Shared surfaces can work in short lengths, cul-de-sacs or where traffic volumes and speeds are low. Usual surfacing material to be block paviers.

Shared surfaces to include an alternative route for the visually impaired. The developer should refer to “Effective kerb heights for Blind and Partially Sighted People” by UCL Accessibility Research Group – 2009. In this document it is recommended to install kerb height 60mm or greater. Any detraction from this recommendation will need to be addressed in Road Safety Audits

Parking spaces within shared surfaces to be clearly delineated e.g. through change of material.

### Footpath Routes

The developer should delineate suitable routes for pedestrians; including those with prams and wheelchairs. These routes should have a firm, non-slip surface and avoid steps even if this means slightly longer ramped routes. Steep cross-falls, gratings likely to trap wheels and obstruction by lighting columns, sign posts etc, should also be avoided. Long ramps should include rest platforms and there should be level areas at the top of each ramp and at every change in direction.

### Width of Footpaths for Prams and Wheelchairs

On footpaths or footways where it is likely that prams or wheelchairs will be used, the width should at no point be less than 1800 mm.

### Demarcation of Highway Boundary

Wherever the extent of the adoptable highway is not clear - for example there is no wall, fence or edging to the footway - then an agreed form of boundary marking to be installed. Usual demarcation to be with brass studs or a row of “hit and miss” granite setts.

### Disabled Persons

It is a statutory requirement to have regard to the needs of disabled people in designing any building to which the public have access. This will include the provision of suitable access routes for wheelchairs and the marking out of parking spaces close to pedestrian entrances for use by disabled people. Disabled parking bays on the public highway should not be integral to the layout design of the development.

### Gradients of Carriageways and Footways

Channel Gradients are not normally to be less than 1 in 120 but may be reduced to 1 in 200 by using channel blocks in order to assist surface water drainage. Slot drains to be avoided.

Minimum longitudinal gradient 1 in 125 for flexible surfacing and 1 in 80 for block paving surfacing. Maximum gradient 1 in 16.7 and 1 in 14.3 for shared surface environments.

Cross sections shall normally be designed at 1 in 40 and a cambered design is preferred. Super elevation should be incorporated in the design of all curves, and in some instances will be essential. The changeover from camber to cross-fall is normally on the straight section of the road.

Longitudinal gradients for footways are normally the same as the adjacent highway. The recommended cross-fall gradients are between 1 in 50 to 1 in 30.

### Vertical Curves

Where changes in gradient occur, vertical curves will be required at crests and sags. Length of curve derived from the formula  $L=KA$ . Where K minimum is 6.5 for a 30mph road and a minimum 3 for a 20mph road. The minimum length of vertical curve is 30m for 30mph and 20m for 20mph. A is the algebraic difference of the gradients expressed as a percentage.

For crests it may be necessary to increase the length of the vertical curve in order to achieve the visibility distance (43m for 30mph and 25m for 20mph).

### Footpath Gradients

For routes designed for pedestrians with prams or wheelchairs, desirable gradients 1 in 80 to a recommended maximum of 1 in 20 and with an absolute maximum of 1 in 12.

### Steps

Steps pose problems not only for those with prams and wheelchairs but also for subsequent mechanised maintenance and should never form the sole pedestrian route. However, since some people find walking on any sloping surface difficult or impossible, steps should be provided in additions to ramps where possible. Flights should comprise between three and twelve steps and longer flights should be split into sections by landings. Steps should be provided with handrails, have permanently non-slip treads, and have a minimum width of 1200 mm clear between handrails.

### Handrails

Handrails should be Equality Act 2010 compliant, contrast visually, be easily gripped, and must be securely fixed. They should be provided at both sides of the steps (or centrally on step 3 m wide or over) so they can be used by either hand, and extended well beyond the top and bottom nosings.

### Highway Profile

The profile of the highway is to be such that surface water will drain naturally into the channels. The footways will fall towards the kerbs with a gradient of 1 in 40 for slabs and 1 in 30 for bituminous materials.

The kerb upstand will generally be 125 mm except where the natural longitudinal gradients of the site are such that false gradients have to be introduced into the channels when the kerb upstand may be varied between the limits of 100-160 mm. 150 x 300mm granite kerbs are the normal. Bus stop kerb heights to be 125-140mm. Concrete kerbs are only used on existing roads where granite kerbs are not used.

The carriageway profile will be determined by reference to 'Gradients of Carriageways' above.

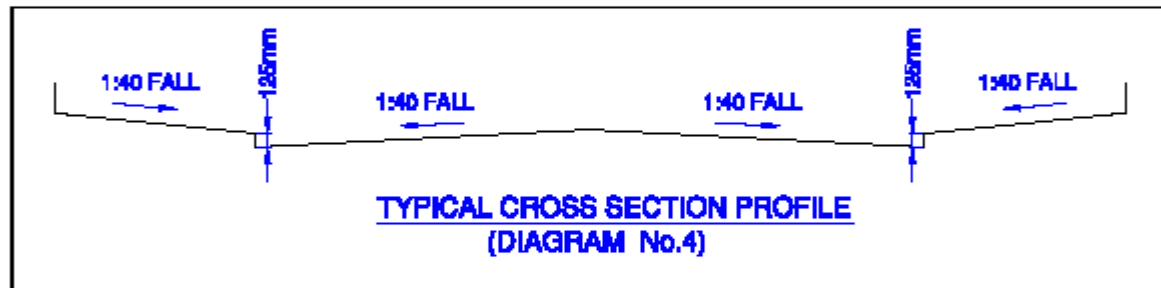

## Kerbs

150mm x 300mm granite kerbs fine picked laid upright, straight and radii, as detail. 300mm flat kerbs only where matching into existing. Natural stone kerbs should be supplied from a single source to ensure consistency. If reclaimed natural rock kerbs are used they shall be redressed before use. If there is a variation in sizes in the supply of kerbs the equivalent sized kerbs must be used together. Kerbs shall be laid on a wet concrete bed or mortar bed.

Re-used granite kerbs to be agreed with the Engineer, or his representative, before laying. The Engineer, or his representative, will determine whether kerbs can be re-used, rejected or are required to be re-dressed. Kerbs to be considered for reuse to be examined for; frost, scuffing, durability or appearance and other damage. Re-used kerbs are not to be mixed with new kerbs and should only be consecutively used. Any impaired kerbs shall be rejected. Where additional reclaimed kerbs are required they should be chosen to match the originals. Older granite kerbs are not often dressed to a standard profile, finish and size and thus should not be mixed with new kerbs. Kerb under 450mm in length will not be considered for re-use.

Precast concrete kerbs will only be used where they match the existing kerbs, on the public highway only, and require the approval of the Engineer. For all extensions to the highway network only be granite kerbs will be accepted. Conservation type kerbs are not accepted as an alternative to granite.

### Granite Setts

The use of large areas of granite setts is to be generally avoided, particularly those with irregular surface. Prior discussion with the Engineer is required at an early design stage where the use of granite setts or pavers are proposed.

In exceptional circumstances where granite paving is used then they shall be 100mm wide and deep bedded and pointed with 10mm mortar mix designated (i) and where in carriageway ramps to be laid with an approved BS 7533 bedding and pointing (eg Instarmac-Ultrascap or similar approved) as referred to in "Design for Pavements" section in this document.

Granite sett delineation of the highway boundary is acceptable.

### Footways and Tree Root Protection Areas

Traditional pre-cast concrete paving is preferred extended kerb to back of footway. Regular traverse bond across to footway at 90 degrees to the kerb (bond stagger 150mm). Mortar infill to be avoided and close butt joints should be provided. Recessed inspection covers in footways where paviors or yorkstone used.

Stronger paving should be used in areas where vehicles are likely to use the footway regularly (e.g. footway parking and in delivery areas). Slabs such as the 400mm x 400mm x 65mm slab can withstand regular use by vehicles up to the maximum legal road-going weight, including vehicles that use stabilisers.

Where the footway works are on an existing footway with trees, then tree roots to be protected during the construction. Flexible footway construction of asphaltic concrete or resin bound material to the tree root areas is required. No mechanical excavation is allowed in a root protection areas (RPA) and excavation and construction to be established with the Council's Arboriculturalist.

### Drainage

Highway drains should, where possible, discharge into the existing Thames Water sewers. The length of highway drainage to be kept to a minimum and should be designed to include only gullies and their connections. The Council's design details for gullies is included in the Lewisham Standard details document. Reference should also be made to Standard Highway Construction Details; F1, F3, F5, F6, F11 and F13.

We will not normally accept a combined kerb and drainage system.

We will not normally accept drainage of other non-adopted areas discharging onto the highway or into an existing or an adoptable highway drain. Downpipes not to be sited within the proposed and existing highway boundary area.



Where private non-adoptable drives and other surfaces fall towards the adoptable highway, the design must prevent surface water run-off from reaching the highway boundary and entering the highway drainage system.

Gullies are to be sited at suitable points at an optimum spacing of 200m<sup>2</sup> of impermeable drained area per gully. At summits the first gully should not be more than 45 m from the high point. Double gullies to be provided at sag points with individual connections to the sewer. Cycle friendly gully covers on designated cycle routes.

Gullies to be sited upstream of the tangent point at road junctions.

Gullies should not be sited directly at pedestrian crossing points, but located where practical upstream of the crossing points.

Gullies should preferably connect directly into manholes, but if this is not possible they shall be connected to the main pipe by 45 degree oblique angled junction or saddled at an oblique angle and surrounded by ST2 concrete mix.

New gullies should not be connected to an existing gully run where they increase the surface water run off area and/or the distance is greater than 5m. Longer distances require a new direct connection.

Gully run lengths to be a maximum of 15m and there should be a separate connection for each gully. A maximum of two gullies is allowed on one carrier drain connection.

Concrete and polypropylene linear type channel drainage to be avoided.

Catch pits or chute gullies are to be avoided and can only be used, on the existing highway where there is insufficient depth to install a pot and they must not connect to another catch pit.

Weir gullies should only be used in exceptional circumstances, and on the existing highway, where there are statutory plant diversions required to install a gully pot and/or where the outlet pipe is directly towards the sewer.

The minimum pipe diameter for adoptable highway drains, other than gully connections, is 225mm. Single gully connections to be 150mm diameter.

Highway drainage manhole spacing's at a maximum of every 50m, change in direction or at connections. Under no circumstances should manholes be laid within carriageway junctions or in roundabouts. The pipe cover shall at least be 1.2m within the carriageway and 0.9m elsewhere. If minimum cover cannot be provided then super strength clay or heavy strength concrete pipe to be provided surrounded by 150mm ST2 mix concrete with flexible joints.

The edge of the excavation for highway drains should not be closer than 600mm to the new kerb line. A minimum of 150mm clearance should be maintained where pipes cross any other piped or ducted service.

Where SUDS are proposed for highway drainage, then the Developer must enter into discussions with all relevant parties at an early stage (and certainly before any planning application) to agree ownership and responsibility for the facility. SUDS often result in higher maintenance costs which will need to be reimbursed through the legal agreement.

Non-standard drainage systems are not usually adopted. Standard drainage systems include; pipes, manholes and gullies. Non-standard systems include culverts, linear drainage, flow attenuation systems, pollution control devices and SUDS.

If the Council adopts SUDS and non-standard drain elements, we will require a commuted sum to cover future maintenance.

#### Dropped Kerbs at Road Junctions

Gradient 1:20 preferred, 1:12 maximum. Width minimum 1.2m.

Provisions should be made at all road junctions for pedestrians to continue along the major road, with a minimum of inconvenience. Kerbs should, therefore, be “dropped”, flush with the carriageway in line with the pedestrian route.

#### Tactile Paving

400 x 400 x 65mm Tactile paving should be installed in accordance with “Guidance on the use of Tactile Paving Surfaces”, Department for Transport. Red at controlled crossings, yellow or charcoal grey at uncontrolled. Ladder and corduroy paving to be charcoal grey. In conservation areas charcoal grey or yorkstone tactiles may be used.

#### Soft Landscaping

Soft landscaping to be limited to trees only with a minimum 14-16cm girth. Species to be agreed with the Engineer. Resin bonded 10-15mm gravel to tree surround with granite or sett edging. 5 year maintenance period will be specified in the Agreement for soft landscaping areas.

Tree pit construction as detailed in Council Standard Details. Alternative, soft cell type tree pit construction will require approval from the Engineer and should only be considered for installation on the existing highway network.

#### Footway Crossings

Light duty domestic vehicular crossovers shall be constructed of concrete (generally grey) block paving and only bituminous surfacing where matching the existing. 150mm x 50mm square-topped precast concrete edgings shall be laid along both edges of the crossover and at the garden boundary, prior to construction of the crossover surfacing.

Heavy duty industrial crossovers shall be constructed as shown in Council Standard Details.

Where vehicular access to premises is taken across a footway the ramped portion should be confined to that immediately adjacent to the carriageway, thus emphasising the pedestrian right of way. The crossing to have a 25mm kerb upstand. The short ramp adjacent to the kerb also encourages a reduction in the speed of vehicles crossing the footway. Vehicular crossovers with high traffic flow to be treated as an uncontrolled crossing at a side road and tactile surfacing should be installed.

### Road Markings

Road markings from hot applied thermoplastic screed with glass beads. All markings in accordance with the Regulations. Generally 75mm thick yellow lines but primrose yellow 50mm thick in conservation areas.

Cold applied, resin binder with aggregate and a 5 year guarantee, line markings (Safetrack LM - GCP Applied Technologies, or similar approved) to be used at junctions and where specified by Engineer for sites with high traffic use and also on traffic calming features.

### Highway Structures (including Basements adjacent to the Highway)

Any proposed structures for adoption or basements adjacent to the highway will require approval by the Council's Engineer. The Approval in Principle (AIP) process is as set out in: <http://www.standardsforhighways.co.uk/ha/standards/dmr/vol1/section1/bd212.pdf>

Further details as required by the Council are included on pages 77-78 of this document.

Where structure are adjacent or on TfL highways please refer to [structurestechnicalapproval@tfl.gov.uk](mailto:structurestechnicalapproval@tfl.gov.uk), for any approvals that are required.

### Drainage associated with the Highway

Where sewers and drainage works have to be provided within the area of the highway, the specification required for their construction shall be in accordance with Thames Waters requirements. The Council's standard details for highway drainage are that in its standard details and that in the Specification for Highway Works.

### Street Lighting

The developer will be required to provide and design the street lighting to standards as set out in the "Croydon and Lewisham Street Lighting Standard Development Specification" updated June 2020. A design pack is required which will show the; highway details, design criteria, maintenance factor, lighting class, design lighting levels. Drawings to be submitted showing the existing and proposed lighting layout. The street lighting Service Provider, Skanska UK Ltd, can be contacted for rates to carry out street lighting design and installation for the Developer. Skanska UK Ltd to be contacted through the Lighting Contract Monitoring Team Manager.

### Street Name Plates

The developer will be required to provide street name plates, as specified, at the end of each new highway.

### Antiskid Surfacing

High friction surfacing on the approaches to signal-controlled junctions, roundabouts and pedestrian crossings are required where it is specifically required by TfL or LBL. At signal controlled crossings a higher PSV 68 surfacing is an acceptable alternative for the borough. Anti-skid surfacing can be bituminous extended epoxy resin with 1-3mm bauxite and the existing road surface condition needs to be appropriate to accommodate this surfacing. Alternatively a resin binder with aggregate to last a minimum of 5 years in high risk areas, as required by the Engineer. This existing surfacing condition to be agreed with the Engineer for any necessary patching works to be carried out prior to applying the anti-skid surfacing.

This high friction surfacing to be applied for a minimum length of 50m ahead of the stop-line on roads subject to a 20 or 30 mph limit, but an increased length may be required due to the approach speed, accident record, average queue length, proximity of side roads and mix of traffic. On approaches to pedestrian crossings the high friction surfacing should be continued past the stop-line to the first line of crossing studs.

To reduce the risk of high friction surface systems failing too soon after application, they are to be applied to a dry surface and where the surface courses have been used by traffic for some weeks before the surfacing is installed.

### Standard Details

Lewisham's Standard Details are to be read in conjunction with this document and can be made available upon request from the Council's Engineers listed on page 79.

### The Specification

The Specification is the current Manual of Contract Documents for Highway Works, 'Specification for Highway Works' published by Her Majesty's Stationery Office in July 2019, including all current Amendments and those modifications or extensions in this document.

Road Construction

For the purpose of these notes the following descriptions of various layers in the construction of a carriageway will apply.

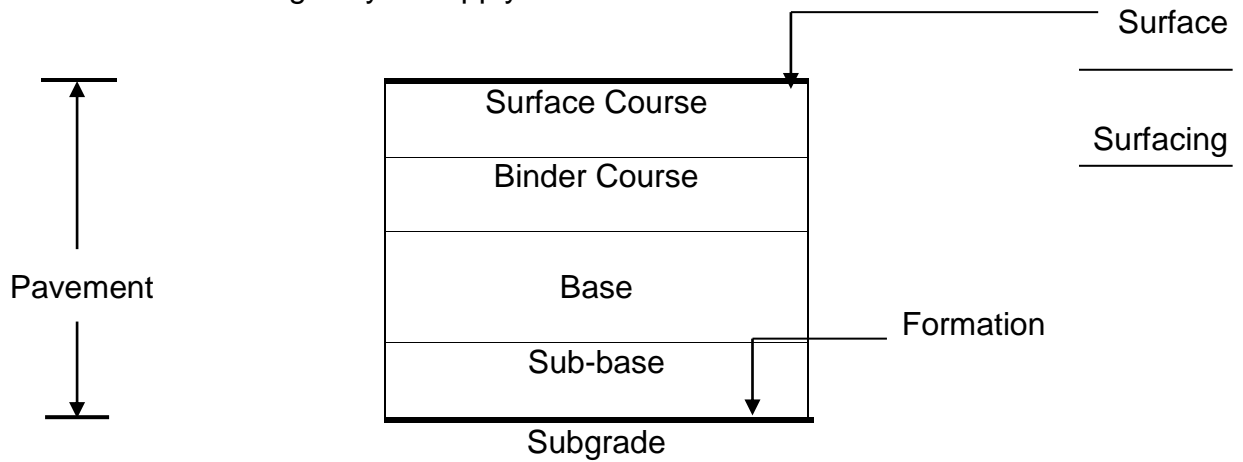

**Diagram 3**

Road pavement upper layers are now subject to design methods and criteria that have been published in HD 26/06 for trunk roads.

Only flexible carriageway construction is acceptable for new residential roads. The following types of materials and depths of construction will normally be acceptable for new roads and on existing roads where works are required. Surface dressing will not be accepted for treatment, where surfacing works have been identified as being required by the Engineer.

**Standard Construction Surfacing**

Single Course Materials

Minimum Thickness

AC 10 close 100/150 surface course	30 - 40mm
Hot Rolled Asphalt (HRA) 30/14F surface course with 14 or 20 mm coated chippings.	40 mm
SMA 6 surf 40/60 PSV 55	20-30mm
SMA 10 surf 40/60 PSV 55 according to road classification surface course (with polymer modified binder where specified by the Engineer)	25-40 mm
SMA 14 PSV 60 or 65 according to road classification surface course.(with polymer modified binder where specified by the Engineer)	35-50 mm
Interlocking Paving Blocks	80 mm on 50 mm sand bed
Surfacing material that offers friction level equivalent to high friction surfaces for approaches to traffic signals or over concrete surface and where specifically specified by TfL.	40mm

Grey or Black Bituminous extended epoxy resin surface dressed with 1 to 3 mm stone – PSV 70.

SMA 6 PSV 55 surface course with bond coat for concrete estate roads only/or where specifically specified by the Council's Engineer 20- 30mm

SMA 14mm with polymer modified binder 75/130-75. 40- 80mm thick  
Single layer material only on the existing highway network where approved by the Engineer

Two Course Surface-Binder Material

*Surface Courses*

AC 10 close surface course	30 -40 mm
HRA 30/14F surface course with 14 or 20 mm coated chippings. Pre-coated red chippings on speed tables	40 mm
SMA 10 PSV 55 surface course	40 mm
SMA 14 PSV 60 or 65 surface course	40 mm

*Binder course*

AC 20 HDM binder course (50-100mm thick range)	
HRA 60/20 binder course (Clause 905) (40-80mm thick)	60 mm
SMA14 ( 30-60mm) or SMA20 (60-100mm) (Clause 0937)	30-100mm

Single Base Course

AC 32 HDM base (70-150mm thick range)	150 mm
AC20 EME2 (90-150mm thick range)	100 mm
Hot Rolled Asphalt 60/32 base (60-150mm thick range)	100mm
Cement Bound Granular Material B (CBGM) (100- 150mm thick range) used if agreed by Engineer	150mm
SMA 20 (50-100mm)	100mm

Regulating

AC 14 Close (Clause 929)	40- 55mm
HRA 50/10 (Clause 904 & 905)	35-65mm
SMA 10 (25-50mm) SMA 14 (30-60mm) (Clause 937)	25-60mm
SMA 6 (15-40mm)	

High Friction Surfacing

HFS (Clause 924)

### Warm Asphalt (WMA)

Where proposed for surfacing then the Engineer's approval is required and is required to comply with Series 0900 of The Specification for Highway Works. The Developer shall submit a declaration of performance of the WMA to the Council prior to approval of WMA.

### Polymer Modified Binders (PMB1) for Surface, Binder and Regulating Courses

To comply with BS EN 14023 with HAPAS Certification.

### Bond Coats

Bond coats shall be used under all asphalt layers. Bond coats shall conform to the requirements outlined in BS 594987:2010 Clause 5.

### Sub-Base

Material used within 450mm of the surface of the road shall not be frost susceptible.

Granular crushed rock or crushed concrete all to the requirements of Clause 803 of the Specification for Highway Works (commonly known as Type 1). Usual minimum thickness in Lewisham is 250mm. Recycled Type 1 to be produced in accordance with WRAP protocol and all documents and certificates supplied upon request by the Engineer, all prior to use on site.

The Developer may be requested by the Engineer to carry out Californian Bearing Ratio (CBR) tests to verify the CBR on site.

Any request by a Developer to take advantage of superior ground conditions may be considered where significant increases in the CBR are available. Any such request should be supported by an approved site investigation report and will require the Engineer's approval.

Where requested by the Engineer, the Developer shall supply a report showing the sulphate content of the site's sub-grade and its classification in accordance with BRE Special Digest No 1, 2005.

CBGM A and CBGM B (Clauses 821 & 822) 50-400mm thick where specifically approved by the Engineer.

### Capping Layers and Geogrids

The capping layer shall be well graded granular natural sands, gravels, crushed rock, crushed concrete, well burnt shales or other material approved by the Engineer. Permitted materials shall be 6F1-5 (Series 600) , Type 2 (Series 800) to comply with the Specification for Highway Works and to be approved by the Engineer.

Material stabilised through cement or lime to be approved by the Engineer at the design

stage.

Where geogrids are proposed then approval will be required at design stage. In suitable circumstances the Engineer will permit the use of membrane/geotextile/geogrid to reduce the amount of excavation and refilling in poor ground conditions.

The Developer shall supply to the Engineer on request details of the proposed product together with calculations to demonstrate the adequacy of the product for the proposed application.

Separation membranes shall be provided when required by the Engineer before filling on soils of low bearing strength.

### Pavements Laid over Existing Surfacing

Where block paving is proposed to be laid over an existing surfacing then the surface shall be perforated by boring holes through the surface using an auger of 50mm diameter. Boring shall continue at each hole until the arisings from the hole include material from the road sub-base or sub-grade. Holes shall be bored at a maximum spacing of 500mm in each direction. Upon completion of boring works, all holes shall be filled with 6mm uniform-size gravel. To prevent lateral movement on carriageways by the blocks then a line of the blocks to be rigidly fixed to surfacing at approximately 10m intervals.

### Rigid Roads

The Council does not accept rigid roads for adoption. If the proposed highway abuts onto an existing concrete/ reinforced concrete borough road, then Developer shall agree proposals with the Engineer prior to submitting design details. Any repairs to concrete roads shall be with HAPAS certified systems.

Standard Highway Construction Details C7/1 and C7/2 to be considered at transitions between rigid and flexible construction.

### Junction Resurfacing

Where a new road meets an existing then consideration to be given for resurfacing the junction. At junctions, this will be over the length from tangent point to tangent point of the junction radii and the extent to be agreed with the Engineer.

### Overbanding

Overbanding between reinstatement materials and the existing road shall be a system to offer a high skid resistance throughout its working life, Clause 711. Overbanding and inlaid crack sealing systems shall have current HAPAS Roads and Bridges Certificates or equivalent. The minimum wet Skid Resistance value of overbanding and inlaid crack sealing systems when newly installed shall not be less than 60.



Acceptable “Standard Construction” Combinations of Base, Binder-course and Surface Courses in Lewisham are:-

TABLE 2

<u>Base</u>	<u>Binder-course</u>	<u>Surface Course</u>
	Bond coat onto concrete, planed or heavily trafficked surfaces.	SMA 6,10 or 14mm PSV 55 (PSV 65 on primary routes).
	(Bitumen emulsion tack coat) on existing dense binder/base or bond coat	SMA 10 or 14mm PSV 60 (PSV 65 on primary routes) or .
	(Bitumen emulsion tack coat) on existing hot rolled asphalt base/binder	Hot Rolled Asphalt 40mm thick with 14mm pre-coated chippings.
	Bond coat on existing dense binder/base or bond coat	AC 10 close surface course, 30- 40mm thick.
	AC 20 dense binder course, 60mm thick	SMA 10 or 14mm PSV 55 (PSV 65 on primary routes) surface course, 30 or 40mm thick respectively.
	AC 20 dense binder course 60mm thick	AC 10 close surface course, 30mm thick.
	AC 20 HDM binder course, 60mm thick	SMA 10 or 14mm PSV 55 (PSV 65 on primary routes) surface course, 30 or 40mm thick respectively.
AC 20 EME 2 up to 150mm thick	AC 20 HDM binder course, 60mm thick	SMA 10 or 14mm PSV 55 (PSV 65 on primary routes) surface course, 40mm thick .
AC 32 HDM base 150mm thick	AC 20 HDM binder course, 60mm thick	SMA 10 or 14mm PSV 55 (PSV 65 on primary routes) surface course, 40 mm thick.
Hot Rolled Asphalt or alternatively AC 32 HDM base (100 or 150mm thick) with 50mm holes at 500mm centres Alternatively 100 or 150mm thick Type 1 or CBGM B.	(Sand bedding Layer) 50mm thick	200 x 100mm interlocking paving blocks, 80mm deep laid to 45 degree herringbone pattern. Or Tegula 160mm gauge type paving in lieu of paving blocks. Stretcher bond with blocks shall be of 120mm, 160mm or 240mm length.
AC 32 dense base 150mm thick	AC 20 dense binder course 60mm thick	AC 10 close surface course, 30-40 mm thick

Hot Rolled Asphalt 60/32,100mm thick	Hot Rolled Asphalt 60/20, 60mm thick	Hot Rolled Asphalt 40mm thick with 14mm pre-coated chippings. Red chippings to speed tables
Polymer modified binder type to be approved by the Engineer, PMB 1. BS EN 14023.		
<b>Acceptable but Non Standard Construction are:-</b>		
150mm thick CBGM B. C12/15 -C20/25	Bedded and pointed with 10mm thick mortar mix designation (i),	200 x100 x100mm, 300x100x 75mm granite blocks, class I igneous rock . (Bond to be agreed with Engineer).
150mm thick C30 or C35 reinforced concrete.	6mm slurry jointing Instarmac or similar approved. 40mm Instarmac or similar approved mortar bedding	200x100x100mm, 300x100x75mm granite blocks, class I igneous rock. (Bond to be agreed with Engineer).

**Trial Holes, Cores & Testing of Existing Surfacing Material**

Cores shall be 100mm nominal diameter prior to and after resurfacing works on the existing highway. Three cores minimum requirement in the length of road to be resurfaced. The position of the cones to be agreed with the Council’s Engineer.

The cores shall generally be cut to prove the bituminous and concrete layers only, but the Developer shall allow for the coring entering lean mix road base and cement bound or granular sub-base prior to resurfacing.

The cores shall be measured in accordance with BS EN 12697-36 : 2003 Clause 4.1. A chemical indication process to be applied to each layer of the core allowing the operator to detect the presence of tar. PAK marker spray to bitumen layers, to determine if PAH levels exceed 150ppm, and UV lamp in cases of doubt after using the PAK marker test. This method to be verified through UKAS accredited laboratory testing. The Engineer to be notified of the presence of Tar and the Developers proposal for its disposal.

Dynamic Core Penetration or Clegg Impact Soil tests to be taken, when directed by the Engineer, in cores or trial pit formation.

Trial holes shall be carried out where request by the Engineer to the existing highway. The location and dimensions of trial holes and cores along with the depths of different types of materials, are to be recorded, and these details reported to the Engineer.

### CCTV Surveys

Where the Developer proposes to connect into the Council's existing highway drainage system the Developer shall arrange a CCTV survey. The survey shall be of any of the drains within the Area as instructed by the Engineer. The word 'drain' is deemed to include highway drains, ducts, and combined kerb block drainage.

The drains shall be inspected by closed circuit television so that all cracks, blemishes, encrustations, open joints, silt, debris, collapsed sections, roots, vermin and alignment can be clearly observed.

All drains shall be cleaned by high pressure water jetting prior to the survey commencing, and any obstructions reported to the Council's Asset Manager.

The Developer shall provide a report and a DVD recording of all drain lengths surveyed showing a record data which can be displayed on a monitor screen. Reports shall be presented in accordance with the format laid down in the 'Manual of Sewer Condition Classification' 5<sup>th</sup> Edition published by WRC, 2013.

### Testing of Sub-Grade and Sub-Base

A sub-base will be required where the sub-grade has a Californian Bearing Ratio (C.B.R.) or less than 20 per cent. That is to say that unless the sub-grade consists of well-drained and well-graded sandy gravel a sub-base will be required.

CBR is an empirical test and is best measured as initially intended although other test devices such as the Cone Penetrometer, the Dynamic Cone Penetrometer and the Plate Bearing Test can be used to determine approximate estimates of CBR.

The minimum permitted Design CBR is 2.5% CBR. Where a sub-grade has a lower CBR it is considered unsuitable support for a pavement foundation and the Developer will be expected to carry out measures to accommodate the poor ground conditions, these measures shall be approved by the Engineer.

CBR Value	Subgrade Strength	Comments
3% or less	Poor	Capping is required. Capping usually up to 600mm thickness where 2.5% CBR encountered. Ground improvement measures if below 2.5% CBR.
3% - 5%	Normal	Widely encountered CBR range and capping to be considered according to road category. Capping usually 250mm to 350mm thickness.
5% - 15%	Good	Capping on heavily trafficked roads usually of 250mm thickness

The depth of sub-base required will depend on the type of sub-grade material. 250mm is the usual minimum thickness for Type 1 sub-base. A low CBR reading indicates a weak subgrade and a thicker road pavement is required. When requested by the Engineer the pavement shall be designed in accordance with the manuals incorporated in Volume 7 of the DfT Design Manual for Bridges. Reference to be made to IAN 73/06 (in conjunction with HD26/06) document.

Road Note 29 can be used for design of lightly trafficked roads and only where agreed with the Engineer.

#### Capping Layer

Where a capping layer is to be provided then this to be Type 6F2 up to 600mm thick.

#### Minimum Thickness of Carriageway Construction

Generally the total depth of construction to be a minimum of 450 mm. The Council may consider a less depth of construction in exceptional circumstances. The table above is for guidance on the use of a capping layer. A construction depth less than 450 mm will only be considered if the sub-grade is proven not to be susceptible to frost.

Where a roadway within a development appears that it may attract traffic of greater volume than would be associated with a normal residential road, the Council may require the developer to provide a carriageway of heavier construction than specified herein, and the specification for such a highway will be agreed by the Engineer.

### Footways and Footpaths Construction

Generally the Council will accept the following types of “**Standard Construction**” footways.

The 600 x 600 (450) x 63mm grey slabs are for use on footways to all roads, major and minor, in both conservation and where on the existing on the highway. A 150mm staggered slab bond is required. Alternatively and generally accepted for new works a stronger slab is required 400 x 400 x 65 mm thick grey Traffica paving slab. All bedded on 30 or 50 mm thickness of sand, on a base of 100 mm thickness of granular sub-base Type 1 material or a Cement Bound Granular Mixture B (CBGM B). A 150mm base will be required where vehicle overrun is expected.

Other acceptable “**Standard Construction**” surfacing for footways and footpaths are shown below:

**Note:** Asphaltic concrete construction requires approval by the Engineer and is only for works on the existing highway where it is required to match the existing.

Concrete blocks, 200 x 100 x 65 mm thick with textured finish or 210 x 105 x 65mm thick clay brick paviors on 30 or 50mm sand, on 100mm Type 1 granular sub-base or a Cement Bound Granular Mixture B. A 150mm base will be required where vehicle overrun is expected. Herringbone bond pattern and any alternative to be agreed with the Engineer. Areas of block paving generally to be restricted to crossovers and at junctions and are not to be used as infill to slabs.

Stretcher bond blue Class B Engineering brick paviors in footways on cement bound granular mixture B sub base, 150 mm thick, bedded and jointed with mortar designation (i).

Precast concrete grey slabs 50mm or 63mm thick, size 450 x 600 or 600 x 600mm size, on 1:3 mortar mix bed 25mm thick or bedded on 30 or 50mm thick sand on CBGM B /granular material Type 1 sub-base 100 mm or 150mm thick.

Where the footway layout may encourage vehicles to mount the footway to park or manoeuvre, then a heavier footway construction will be required or other measures taken to prevent damage. Such measures include; 80mm concrete blocks on 30 or 50mm sand and a 150mm thick sub-base or alternatively 30mm AC 10 dense surfacing on 60mm thick AC 20 dense binder course on 150mm thick Type 1.

Vehicular footway crossover 25mm AC6 on 150mm thick ST2 concrete mix.

Heavy duty crossovers construction include 40mm thick with 20mm coated chippings HRA 35/14 surfacing course on 60mm thick HRA 60/20 binder course on 250mm Type 1 sub-base . Sub-base of 375mm thick with geogrid where CBR 2% or less.

Asphaltic concrete (AC6) dense surfacing 25mm thick on 100mm or 150mm thick cement bound granular mixture B sub-base.

SMA 6 in lieu of AC6 where machine laid in footpaths.

Asphaltic concrete (AC6) dense surfacing 20mm thick. AC14 dense binder 50 mm thick on 100mm or 150mm thick granular material Type 1 sub-base. Flexible construction to be used in footways with problems associated with existing tree roots. Buff resin bonded surfacing is “non standard” and only to be used where agreed by the Engineer.

Other acceptable “**Non Standard Construction**” surfacings for footways and footpaths listed below.

Note: Locations are specified and when used outside these areas it will be subject to a commuted sum.

100 x100 x 200mm granite or tumbled blocks or sawn cut setts laid in stretcher bond (or that agreed with the Engineer) 25mm bed and pointed with 10mm thick mortar mix designation (i), laid on 100 or 150mm thick CBGM B. Where used as an edging then setts to be laid on 150mm ST1 concrete. This construction only accepted in occasional circumstances, such as conservation areas.

Granite paving in footways 100 x 100 x 200mm, 300 x100 x 75mm, 400 x 400 x 75mm or 300 x 400 to 800mm x 75mm ( size and colour including mix can be varied but with the Engineer’s approval) in stretcher bond laid on 40mm Stein Tec Tuffbed or similar laid on 150mm thick C32/40 concrete. Generally large areas of granite paving is only to be used where it currently exists on the public highway such as in; Lewisham Shopping Centre, Catford Broadway and Deptford High Street.

Yorkstone paving in random lengths and varying widths, 50 or 75mm thick pointed with 1: 3 mortar on 25mm mortar bed on 100/150mm ST5 concrete sub base. Generally yorkstone shall be Natural York Stone Paving Sawn Cut Slabs to be BS EN 1341, minimum density 250 kg/m<sup>2</sup>, with compressive strength obtained from BBS Ltd or Marshalls and is only to be used where it is currently on the existing public highway such as Lewisham Shopping Centre, Blackheath Village and Sydenham Town Centre.

Witherford reinforced paving slabs 750 x 600 x 63mm shall be used where it is currently on the existing public highway as in; Sydenham Town Centre, Ladywell Village, Dartmouth Road and at Crofton Park Station. This to be bedded on 40 or 50mm thick 1:3 mortar screed base on 150mm CBGM B.

Perfecta 400 x400 x80mm paving by Marshalls to be used in and around the Lewisham Shopping Centre area .

Charcon Commercial Landscaping and Eco-Block 200 x 100 x 80mm to be used in Sydenham Road only.

Red AC6 surfacing 30mm thick to paths in parks only used where matching the existing surfacing.

Charnwood paving slabs 400 x 400, 65mm thick, on 30 or 50mm sand on 100 or 150mm Type 1 to be used on the Cycleway (Quietways 1) route.

Pallas 400 x400 x80mm paving on 30 or 50mm sand on 100 or 150mm Type 1 by Marshalls to be used on the Cycleway (Quietways 1) route, in roads around Lewisham Town Centre and in Creekside (600 x300 x 65mm).

2-5mm Addagrip corn flint resin bonded surfacing to asphaltic concrete surfacing to be used on designated cycleways and where required by the Engineer.

Hot-applied resin bonded paving 6/10mm gravel at a depth of 20-25mm on AC14 dense binder 50mm thick on 100 mm Type 1 sub-base.

Breedon Gravel to be laid 75 mm thick and compacted to 50mm thick on 150mm Type 1, with weed suppressant membrane to the formation. This surfacing only to be laid in footpaths and in open spaces.

### Construction –General Acceptable **Standard** Highway Materials.

Standard 600 x 600 x 63mm or 600 x 450x 63mm grey paving slabs by Marshalls Plc or similar approved.

Paving shall be 400 x 400 mm, 65 mm thick chamfered grey slabs, manufactured by Marshalls plc, Ref. FL1650750.

Tegula paving shall be 160 mm gauge, 80 mm thick, manufactured by Marshalls plc, and shall be of the colour and laid to the bond pattern specified. Blocks shall be Red Charcoal or Pennant Grey of 120mm, 160mm or 240mm length.

Asphalt surfacings as specified in this document.

Granite Kerbs, channels, edging and quadrants various sizes.

Trief Kerbs 380 x 415mm with reinforced backing. Granite trief where specified by the Council.

Precast concrete edging 50 x 150 (or 250mm depth).

Hexham Bollards by Bollards Ltd or Furnitubes Ltd, with inset reflective bands.

Bell Bollard Bell 1100 by Furnitubes Ltd.

Harrogate Cycle Stand by Broxap Ltd.

The Broxap Sheffield or Slanted Sheffield.

Furnitubes 'Hammersmith' cycle stands.

Street name boards by Signway – Lewisham specification.

Flecta or Flecta Heritage “keep left” traffic island bollard by TMP Ltd.

Grey concrete block pavements 65 or 80mm thick by Marshalls or Charcon.

Clay pavements (type and colour to be approved by Engineer).

Lighting details, refer to the Skanska PFI details.



Two weeks 'written' notice of the Developer's intention to commence the highway construction must be given to the Engineer in order that arrangements may be made for the Council's inspection of the various stages of the works.

An assistant Engineer or other appointed Representative of the Engineer will supervise the construction of the highway in accordance with the specification, and every facility must be afforded by the Developer to this end.

The Developer or his contractor shall give at least 48 hours notice (i.e. 2 working days) of the commencement of the various stages of construction as listed below. Such notice is to be repeated after any works have been temporarily suspended. No covering up of these work stages may be undertaken until approval has been obtained by the Engineer or Representative for:

- commencement of works
- the sub-grade to footways, footpaths, cycleways and carriageways
- the sub-base (and capping layer, where necessary) to footways, footpaths, cycleways and carriageways
- highway drainage (see below)
- kerbing and edging
- street lighting and signs
- laying of base course
- laying of binder course
- laying of surface course
- landscaping

The onus of responsibility will rest with the Developer to advise the Council's supervising officer when the Developer considers that the highway has been completed and is ready for inspection.

1. General

All work must be carried out in an efficient and workman like manner to the entire satisfaction of the Engineer. The Developer must employ a competent foreman in charge of the work to see that instructions given from time to time by the Engineer or his representative are properly interpreted and carried out.

All materials used on the works shall be the best of their respective kinds and shall conform to a standard not inferior to the latest appropriate British Standard and European Standards. Throughout this Specification reference to a British Standard and European Standards is to the latest edition with all subsequent amendments. So far as practicable all materials used in the works shall be of British origin or manufacture.

2. Samples

Before commencing the works, and if the Engineer requires, the Developer shall at no cost to the Council deposit at the Engineer's office samples of any materials that it is proposed to use in the works. No materials of which samples are required shall be used until the samples have been approved. The samples will be retained by the Engineer during the progress of the works for the purposes of comparison. All materials subsequently used in the works by the Developer shall be equal in every respect to the deposited and approved samples.

3. Concrete Road Pavements (Used only where tying into existing)

Concrete for road pavements to comply with Series 1000 of The Specification for Highway Works.

Sampling and testing for, and compliance with the specified characteristic core strength of designed concretes shall be undertaken by compressive strength testing in accordance with BS EN 13877-2 on cores cut from the full depth of the slab.

4. Cement

Unless otherwise ordered or directed cement shall be ordinary Portland cement complying with BS EN 197-1. Where sulphate-resisting or rapid-hardening cement is required it shall be of an approved brand and shall satisfy such tests as the Engineer may specify.

5. Sand

The sand is to be free from loams, silt, and deleterious matter, that for concrete and laying course is to comply with BS 882 and that for mortar with BS EN 13139:2002.

For laying course sands, the usual specification followed is that given in BS 7533:Part 3.

For paving slabs, a sand complying with grade C or M of BS882 (Pavement Category 2 or 3).

Jointing sand to be used to fill the joints of block paving and to be selected to have a very low clay content and have grain sizes that will generate a high degree of friction, thereby giving stability and resistance to loading in a block pavement.

6. Concrete Aggregates

Aggregates for all pavement concrete, including wet lean concrete, shall comply with BS EN 12620.

7. Granolithic Concrete

Aggregates shall comply with BS EN 12620: 2002. Fine aggregate shall be sand resulting from the natural disintegration of rock.

Granolithic concrete shall consist of two parts of 10mm granite or whinstone chippings and one part of sand to one part of Portland cement by weight .

8. Water

All water used in mixing concrete shall be obtained from Thames Water Authority.

No chemicals or other additives shall be added to the water and the temperature of the water shall not be raised by artificial means without prior approval of the Engineer.

The water for each batch shall be measured and shall be just sufficient to ensure the production of concrete of the required consistence.

9. Cement Mortar

Cement mortar, unless otherwise specified or directed, shall be composed of cement and sand mixed in the following proportions:-

<u>Normal Mix</u>	<u>Cement</u>	<u>Sand</u>	<u>Use</u>
1:1	50 kg	0.035 m <sup>3</sup>	Kerb Jointing
1:2	50 kg	0.070 m <sup>3</sup>	Pipe Jointing
1:3	50 kg	0.105 m <sup>3</sup>	Brickwork below ground

10. Cement Bound Granular Material

Required Mixture ; CBGM B  
 Aggregate Requirements; LA<sub>50</sub>  
 Compressive Strength R<sub>c</sub>; C 12/15

11. Bollards

Specialist bollards include bell and ½ bell bollards by Furnitubes International Ltd.

Flecta of Flecta Heritage bollards by TMP Ltd are specified for traffic islands.

Permanent bollards, with reflective bands - Hexham as supplied by Bollards Ltd.

Timber bollards as shown in standard details with reflectorised banding as required.

12. Cycle Stands

The Broxap Sheffield or Slanted Sheffield, Broxap 'Harrogate', Furnitubes 'Hammersmith' cycle stands as standard details.

13. Concrete Channel Blocks

Where used, concrete channel blocks shall be 250 mm x 125 mm to be laid flat.

14. Granite Setts

Granite Setts shall be cropped 100mm cubes or 100 x 100 x 200mm granite sawn cut (and tumbled), in accordance with B.S. 435. Tumbled blocks not to be laid in large areas where sawn sided or cropped topped are preferred and to be agreed with the Engineer

15. Granite Kerbs

Granite kerbs, channels and quadrants shall comply with BS435: 1975 with Standard Dressing A (fine picked).

Joints between kerbs, channels and quadrants shall be pointed with mortar designation (i) as described.

Granite kerbs for re-use shall be agreed with the Engineer.

16. Paving Slabs

Grey Traffica paving slabs to be 400mm square 65mm thick chamfered grey slabs, manufactured by Marshalls Plc.

General grey paving slabs 600mm square or 450mm x 600mm, 63mm thick slabs by Marshalls Plc.

Paving within any area shall generally be obtained from the same source. The Contractor shall not change supplier within any area, without approval from the Engineer.

17. Specialist Paving : Precast Concrete ,Yorkstone, Breedon Gravel, Resin bonded surfacing

Reinforced paving shall be fibre-reinforced. Slabs shall be either 450 x 600mm or 600 x 600mm, 63mm thick, with chamfered edges and shall be laid in accordance with Clause 1104. 50mm slabs can be laid at rear of path.

Charcon Witherford paving slabs 750 x 600 x 63mm .

Tegula paving shall be 120/160/240 mm gauge, 80 mm thick, manufactured by Marshalls Plc, and shall be of the colour and laid to the bond pattern agreed with the Engineer. Blocks shall be of 120mm, 160mm or 240mm length.

York Stone paving in Lewisham High Street shall be "Greenmoor Rustic" "flame-textured" slabs, sawn on all faces, from Marshalls Plc or Natural York Stone Paving, Ref S35 / 489A, obtained from CED Ltd.

York Stone paving at any other location shall be Natural York Stone Paving Sawn Cut Slabs to be BS EN 1341, minimum density 250 kg/m<sup>2</sup>, with compressive strength obtained from:- BBS Ltd or Marshalls.

Yorkstone Paving shall be laid in accordance with BS 7533 Part 4.

Granite Paving size and colour can vary and to be agreed with the Engineer.

If the Contractor proposes to use an alternative supplier for any of the above paving materials, he shall submit samples to the Engineer for his approval.

Breedon Gravel to be laid at a compacted thickness of 50mm onto compacted 150mm Type 1 sub base. A weed suppressant membrane to be installed under the sub base. The Breedon Gravel should be spread using a flat board or the back of a rake and compacted with a 1.5 to 2.5 tonnes vibrating roller. Once uniform then the gravel to be water rolled.

18. Geogrids and Textiles

Geotextile Tensar AR-G or equivalent laid, where required, in base or binder course.

Geotextile Tensar SS2 or equivalent laid, where required, in sub-base or capping.

Geotextile Terram 1000 or equivalent laid, where required, in sub-base or capping.

19. Granular Sub-Base Material

The granular sub-base material shall comply with the Clauses of Series 800 in the Specification for Highway Works. Unbound mixture Type 1 and 2 as Tables 8/5 and 8/6 respectively.

The Engineer's approval is required where recycled material is proposed.

**BASE COURSE**

20. Hot Rolled Asphalt

Hot rolled asphalt base course 60/32, 100 or 150mm thick. Paving bitumen 40/60. BS EN 13108-4:2006

Aggregate to be crushed rock only to grading Table 1 Nom. size 32mm.

To comply with Clause 904 of the Specification for Highway Works.

21. Asphaltic Concrete Base 32

Asphaltic Concrete Base 32, 100 or 150mm thick. BS EN 13108-1:2006. Paving grade bitumen 70/100

Aggregate to be crushed rock only to grading Table 1 or 2 Nom. size 32mm.

Clause 929 of the Specification for Highway Works

To comply with Clause 903 of the Specification for Highway Works for placing and compaction.

22. Asphaltic Concrete 32 Heavy Duty Macadam Base

As for Asphaltic Concrete Base 32 with binder of paving bitumen 40/60.

**BINDER COURSE**

23. Hot Rolled Asphalt

The Hot Rolled Asphalt binder, 60mm thick. BS EN13108-4:2006 594. Paving bitumen 60/20 binder. Aggregate to be crushed rock only to grading Table 1 nominal size 20mm. Shall comply in all respects with Specification for Highway Works Clause 905

24. Asphaltic Concrete 20 Dense Binder

Asphaltic Concrete, 60mm thick layer to comply with BS EN 13108-1:2006. Paving bitumen 70/100. Aggregate to be crushed rock only to grading Table 1 or 2 Nom. size 20mm. Binder content 4.6%. Void content to Tables 3 & 4 –  $V_{max5}$ ,  $V_{min2}$ . 10% fines of coarse aggregate to be 120 kN min. Recovered binder penetration to be not less than 70% nom. value when tested within one month of laying. Specification for Highway Works Clause 906.

25. Asphaltic Concrete 20 Heavy Duty Macadam Binder

As Asphaltic Concrete 20 Dense Binder with binder paving bitumen 40/60. Specification for Highway Works Clause 929.

**SURFACE COURSES**

26. Stone Mastic Asphalt

Stone Mastic Asphalt surface course shall be 6mm, 10mm or 14mm Nominal Size and shall comply with the general requirements of Clause 942 of the Specification for Highway Works. BS EN13108-5. Course and fine aggregate shall be crushed rock complying with Clause 901. Paving bitumen 40/60 binder. 40mm thick and PSV 60 for residential roads and 65 for principal roads.

27. Hot Rolled Asphalt

The Hot Rolled Asphalt wearing course shall comply in all respects with BS EN13108-4:2006 594. Paving bitumen 100/150. 40mm thick. Course aggregate to be crushed rock only (excluding limestone) to grading Table 4 nominal size 14mm. Minimum PSV 55, AAV 10 maximum.

Hot Rolled Asphalt (HRA) 30/14F surface course with 14 or 20 mm coated chippings Clause 915 and 943 of the Specification for Highway Works.

28. Asphaltic Concrete 10 Surfacing Course

Asphaltic concrete close surface course, 30-40mm thick, 10 mm nominal size. Paving bitumen 100/150. BS EN 13108-1:2006. Aggregate to be crushed rock only (excluding limestone) to grading Table 2 Nom. size 10mm. Binder content 6.2%. Min. PSV 55. A.A.V 12/14 .

29. Chippings

Coated chippings to be to BS EN 13108-4:2006, Annex C, nominal size 14mm or 20mm. P.S.V 50 min. A.V.V 10 Max. Red and red coated chippings to speed tables.

30. Gritting

When directed by the Engineer, the surface course shall be gritted with 75micron to 3mm dust free or very lightly bitumen coated crushed rock fines at a rate exceeding 600gms/m<sup>2</sup> before final compaction is complete and rolled in. Excess material shall be removed by sweeping.

31. Regulating Course

SMA 6 (15-40mm thick), SMA10 (20-50mm thick), SMA14 (30-60mm thick), HRA 50/10 (35-60mm thick), HRA 50/14 (35-65mm thick)

Where regulating material is more than 100mm thick the top 40mm shall be laid as a separate course .

32. Bond Coats

Bituminous emulsion sprays for use as tack coat shall be class K1-40 and bond coats K1-50. The rate of spread shall be as follows:-

On Newly-laid Surfaces - 0.15 -0.25 kg/m<sup>2</sup>

On Planed Surfaces – 0.15-0.60 kg/m<sup>2</sup>.

Higher spread rates may be applied at the kerb face where less compaction occurs and water ingress may be a problem.

33. Road Markings

Road markings to be white thermoplastic screed with applied solid glass beads. Continuous line in yellow thermoplastic screed width of 75mm and primrose yellow 50mm thick in conservation areas. All in accordance with the Traffic Signs and General Directions 2002 and Amendments 2011.

34. Paving Blocks

Concrete paving blocks must conform to the specification of BS EN 1338 and clay blocks to BS EN1344.

Blockley clay pavers 210 x105 x 65mm. Marshalls block paving, 200 x 100 x 65mm but 80mm grey blocks for crossovers and carriageways.



35. Steel Reinforcement Bars

Reinforcement bars shall be to lengths and shapes as shown on the contract drawings and comply with either BS EN 4461:2007 or BS 55628 : Part 2 1985 for reinforced masonry.

36. Steel Reinforcement Mesh

Steel reinforcement mesh for footway crossovers etc shall comply with B.S. 4483 2005.

37. Dowel Bars

Dowel Bars to accord with the sizes in accordance with Highway Construction Details. 20 or 25mm diameter for contraction joints and 25 or 32mm diameter for expansion joints.

Tie bars for warping joints and traverse joints to be 12mm diameter or 750mm and 1000mm length respectively.

Tie bars 20mm diameter ,1000mm long at 300mm centres for rigid to flexible construction.

38. Sign Specification

Only traffic signs manufactured and authorised by the Department for Transport specifications will be approved.

The signs shall conform to the Traffic Signs Regulations and General Directions 2016.

39. Bricks

All bricks used in the construction of drainage works shall be Engineered Bricks complying with BS 3921 Class B. They shall be carefully handled and stacked on site.

40. Drainage

Precast concrete trapped gully 1.05 m deep with Grade A cast iron, heavy duty cover and frame as details.

Chamber specified design group Types 1, 3a, 4a of The Specification for Highway Works standard details with heavy duty cast iron Grade A cover and frame.

Sumpless "Chute" gullies can be used where connecting to existing gully pot and require Engineer's approval .

41. Pipework and Ducts

100mm or 50mm service ducts as details on bed Type T. Orange ducts for street lighting and EDF ducts are to be black.

150mm internal diameter vitrified clay super strength drain or sewer on bed and cover Type Z or Type S acceptable where exceeds 1.2m.

42. Drainage Covers and Frames

Manhole Covers and Frames in carriageways to be heavy duty cast iron Grade A cover and frame double triangular. In footways and open spaces they shall be Grade 'B' flat type medium duty rectangular covers and frames (Typical size 600 mm x 600mm and 900 x 600mm for drainage manholes) or recessed medium duty galvanised fabricated steel 76mm deep recessed cover.

Refer to BS 497 : Specification for manhole covers, road gully gratings & frames for drainage purposes.

All new gully gratings and frames shall be hinged at the kerb side and have a bar pattern which is "cycle friendly".

Ductile iron covers will not be permitted..

43. Guardrailing

Generally these are not installed in the borough except when replacing the existing. Hugh Logan Engineering 'Visirail V2' guardrail or similar approved.

Furnitubes 'Linx' 100 guardrail with Visi-posts or similar approved.

44. Cycle Stands

Broxap Sheffield/Harrogate/Hammersmith cycle stands with duracast or plastic coated finish. ST1 150mm concrete foundation to legs.

45. Street Name Plates

Street name plates will be provided in positions agreed by the Engineer. Street name boards as supplied as Signway White name boards with black text (street name) 90mm Frutiger, blue- London borough and post code 40mm colour c:100 M:70 Y:0 K:0.

46. Expansion Joint Filler

Expansion jointing is to be 12.15 mm thick "Flexcell" or other equal and approved performed expansion joint material delivered in flat sheets.

47. Expansion Joint Sealer

Expansion Joint Sealer is to be “Expandite” or other approved joint sealing compound. Specification for hot applied joint sealant for concrete pavements to BS2499.

48. Tree Pits and Tree Pit Paving

Tree pit standard details for Lewisham are shown on standard drawing HAT\SD\300\01. Alternative, cellular type (GreenBlue Urban) construction pits to be approved by the Engineer.

Hand floated resin bonded paving 3-10mm stone size aggregate, 50mm thick on 100mm free draining crushed stone (Type 1) on tree soil sub-base. Clearmac or similar approved by the Engineer. Alternative Addastone TP Resin Bound tree pit system , 25-75mm thick.

49. Top Soil

Top soil as Specification for Highway Works Clause 618 and Class 5 Table 6/1. Top soil required in areas of planting and grassing shall be good clean friable sandy loam having a high organic content and shall be free from weeds.

Topsoil depth shall be 150mm and spread, graded and consolidated by hand or mechanical means. Imported soil to comply with BS 3882:1994.

Turf

50. Turf as Specification for Highway Works Clause 3005 .12.

Turf shall be the best quality cultivated meadow turf free from weeds.

51. Street Lighting General

The developer to refer to the “Croydon and Lewisham Street Lighting Standard Developers Specification” for details, design, installation, costs and specification.

52. Feeder Pillars

Refer to TOFCO manufacturers website. Catalogue Reference FP1- 100 Series, FP2- 300 Series. Galvanised Mild Steel ( finish black).

53. Standard Lighting Columns and Brackets

Contact Mallatite for details of specification. Hot dipped galvanised and thermoplastic anti-corrosion – gloss black.

54. Standard Lantern Units

Contact Phillips Lighting for details. Luminaire canopy - aluminium finished with black gloss. Lamp types CPO or SON-T.

55. Traffic Signs and Bollards

Illuminated traffic signs, manufacturer Simmonsigns Ltd. LUA/LUB LED Range. Cast Aluminium construction IP%\$ tamper resistant access.

Non illuminated bollards, manufacturer Traffic Management Products (TMP). Flecta/Solatite Range- product ref:101601. Material :vacuum formed polypropylene.

56. Understanding of the Specification

If the Developer is unclear as to the meaning or intent of any item of this specification he should consult the Engineer or his representative and obtain a decision prior to detailed design and site works proceeding.

57. Traffic Management

If the nature of the works is such that specific Traffic Management measures are required on the public highway, the Developer shall submit his proposals for traffic safety and management to the Network Co-ordinator before commencing works on a highway open to vehicular traffic. Existing carriageway widths shall be maintained for as long as practicable. A general width of 6.5m minimum is required to maintain two-way traffic. Where this is impractical alternate one-way working may be introduced with the agreement with the Metropolitan Police Traffic Division and the Council's Traffic Manager or Network Co-ordinator.

When directed by the Network Co-ordinator it may also be necessary for the Developer to incorporate within his traffic management scheme alterations or additions to advance direction signs. Where a vehicle or pedestrian route, existing or temporary, is adjacent to the works, safety barriers shall be provided between the route and the works. These barriers shall be removed only when necessary to complete the works. Temporary traffic signals may only be used with the prior approval of the Network Co-ordinator and the Police. They shall be supplied with the electricity from a temporary supply by EDF from a lamp column or battery operated. The use of generators will generally not be permitted.

The Developer is responsible for all traffic management. Most works on the existing highway will require only signing and guarding in accordance with Chapter 8 of the Traffic Signs Manual. The Developer is reminded that of Chapter 8 Clause 1.3 – Legal Requirements.

58. Temporary Fencing

Temporary fencing 'Heras' or similar 2.4 m high.

59. Supervision of works on the Public Highway

The Developer to provide the Council details of the Supervisors whom shall be 'Accredited Supervisors' for works in the public highway. The Developer should ensure that all Supervisors and Operatives working on the public highway are qualified in accordance with the requirements of the Street Works Regulations 2009 and shall be holders of the relevant Construction Skills Certification Scheme card as issued by the CITB.

60. Sampling and Testing of Materials

The Developer must arrange and pay for all the sampling and testing as required by this document and the Specification for Highway Works. One copy of these test results to be submitted to the Engineer.

The Engineer reserves the right to carry out any sampling and testing he or she feels is necessary to confirm that the goods and materials meet with the Specification. The Engineer, acting reasonable, may ask the Developer to core through any pavement construction at any stage to check the thickness of the layers and the type and standard of construction. If the work does not meet the Specification, then the Developer will be required to rectify. Such coring will be paid for by the Developer.

61. Cleanliness of the Highway

All public highways including carriageways, footways, footpaths, and verges used by the Developer shall be kept clean, free from dust, mud and debris of any description to the satisfaction of the Council or the Police. The Developer shall employ such equipment, mechanical or otherwise, as is necessary to clean the highway and/or the wheels of vehicles.

62. Storage of Materials and Items Removed from the Highway

The Engineer shall assess whether any of the materials and equipment from highway site clearance needs to be carefully dismantled for re-use. The Engineer may instruct that they are taken to the Council's or its contractor's depot.

On such occasions it may be necessary for materials, items or things removed from the highway to be placed in temporary storage rather than taken for disposal. The Developer will be required to adopt methods of loading, transporting, unloading and storage which do not cause damage, breakage or deterioration to such materials, items or things and will be required to provide storage space at his depot suitable for storage. The Developer shall provide a summary sheet giving details of all materials, items or things to be held in temporary storage on the public highway. He shall obtain in advance the written approval of the Engineer to his precise proposals and storage areas shall be agreed with the Engineer for each work location. Materials shall be stored or stacked and kept in a neat and tidy fashion in places so as to cause the least interference possible to the public.

Storage of materials, plant and equipment on highway structures shall only be permitted with the prior approval of the Highways Engineer. In certain circumstances, a formal technical approval submission may be required in advance of the works or phase of the works commencing.

The Developer shall accept full responsibility for any damage or accident caused. Under no circumstances shall any materials be left on carriageways or footways during the hours of darkness without adequate fencing and lighting.

All materials required to be disposed of shall be removed from the site each day, unless agreed otherwise by the Engineer or representative.

63. Management of Works on the Public Highway by the Developer

The Developer shall take all necessary precautions to prevent danger, nuisance or inconvenience to the owners, tenants or occupiers of adjacent properties and to the public generally.

The Developer shall, during the whole time that works are in progress, keep the whole of the site clean and in a tidy condition, and shall remove all material to be disposed of on a daily basis unless agreed otherwise. Particular care shall be taken to ensure that no materials enter drainage gullies. All water pumped from trenches or other excavations shall be confined to proper channels and shall not be permitted to flow across roads or footways. The attention of the Developer is drawn to the likelihood of damage occurring to highway surfacing by oil deposits from stationary and standing plant. Any such damage shall be made good at the Developer's expense to the satisfaction of the Engineer.

The Developer shall keep all fire hydrants, stopcocks, manhole covers, electricity supply boxes and all other Public Services readily accessible and free from all obstruction.

The Developer shall take all necessary steps to avoid creating a dust nuisance, and shall ensure the works are carried out in accordance with the GLA and London Councils publication "The Control of Dust and Emissions from Construction and Demolition; Best Practice Guidance (2006) and any revisions.

The Developer shall keep all roads, private entrances, verges, paths, footways, drains and ditches free from mud, slurry or other material that is deposited through his operations. If mud or other droppings are deposited on the highway by vehicles used in connection with the contract, the Developer shall forthwith cleanse the streets to the satisfaction of the Council's representative.

Only such quantities of plant and materials as are necessary for the proper progress of the works shall be kept on a site at any one time. Plant and materials shall be placed only in such places as the Developer may allow, and all materials shall be kept neatly stacked or trimmed. The Developer shall temporarily remove from site all plant and materials if circumstances arise which, in the opinion of the Engineer, make such removal necessary.

The Developer shall obtain the approval of the Engineer or representative to the siting of any huts, equipment, stacks or heaps within the public highway.

The Developer shall make his own arrangements, including applying for planning permission, with the owners, tenants and occupiers concerned for the use of any private land for plant, stores, working space or spoil dumps.

On completion of the highway works, and before departing, the Developer shall clear the site of all rubbish, materials, etc and generally eliminate all signs of his presence on the site and leave it in a clean and tidy condition to the satisfaction of the Engineer or representative. All areas used for the storage of materials and site offices shall be reinstated to the Engineer's satisfaction at the Developer's.

Existing traffic and pedestrian flows shall be maintained at all times except where agreed with the Network Co-ordinator.

The Network Co-ordinator shall be given 48 hours notice of the Developer's intention to switch traffic phases, and no diversions shall be implemented until the measures associated with the previous phase of work have been fully removed.

All temporary traffic routes and access arrangements shall be co-ordinated with the Network Co-ordinator, the Police and the other Emergency Services.

Road closures and diversions shall be co-ordinated with bus operators. One week's notice of the timings of changes to traffic phasing's and diversion routes shall be given to allow bus operators to plan alternative routes. Existing bus stops shall remain operational at all times unless temporary stop positions are agreed. Safe pedestrian routes and crossing points shall be maintained to all permanent or temporary bus stops while these are in use.

Clearly defined pedestrian routes shall be maintained at all times. These routes shall be signed, fenced and lit. Pedestrian access shall be maintained to all adjacent properties at all times.

The Developer shall have permits to work on the highway – refer to pages 17 and 18.



64. On – Site Accommodation and Equipment for Highway Authority’s Engineer.

For larger scale projects with highway works of value over £500,000 then temporary accommodation to be provided when directed by the Engineer. The Specification of the accommodation and equipment will be provided upon request.

65. Control of Noise and Vibration on the Existing Highway

Unless otherwise authorised or directed by the Engineer, works on the public highway shall not be carried out outside the hours of 0800 to 1700 Monday to Saturday. On traffic sensitive roads some work will be restricted between the hours of 9:30am and 3:30pm. The Developer to check with the Network Co-ordinator prior to programming his work on the restrictions required by the Council.

Unless otherwise authorised by the Engineer, the breaking up of hard material will not be permitted before 0830 or after 1630 hours.

Whilst carrying out breaking operations the Developer shall have due regard for the comfort of pedestrians, shop and office workers and residents. He shall ensure that the following measures are carried out:-

- (a) All plant is silenced at all times with effective silencers. As far as practicable, all sources of noise from plant shall be enclosed and adequately insulated. Acoustic barriers shall be used to shield noisy operations wherever possible
- (b) Whilst breaking out kerblines or the like, compressors or other static plant shall be positioned away from buildings, whenever possible, and shall be relocated as the work proceeds, to ensure that noise nuisance is not suffered continuously by one address.

66. Setting Out

The Developer shall be responsible for setting out the lines and levels of the new carriageway, drains and all other work in accordance with the approved drawings.

The Developer shall afford the Engineer of representative the use of surveying equipment to check the setting out, where required .

67. Drains and Supply Mains

The Developer must ascertain the exact position of all sewers, water, gas, electricity, telecommunication and other mains by means of trial holes or otherwise before commencing the work. The Developer shall make all necessary provision for protecting and supporting or diverting such supply mains, etc, as may be encountered.

68. Drainage Connections

Junctions shall be formed using purpose made 45° oblique junctions of appropriate size. Where connections are to be made to an existing pipe, purpose made saddles may be used, with the prior permission of the Engineer or Thames Water as appropriate. They shall be properly mortared in, ensuring no mortar enters the main pipeline, and the hole surrounded with 150mm of Class ST4 concrete. Where necessary a pipe shall be removed from the main line and replaced with an approved purpose made junction pipe.

Where required, existing sewers and drains shall be properly extended, connected and jointed to new sewers, culverts, drains or channels.

Before entering or breaking into an existing sewer or drain, the Developer shall give notice of his intention to do so to the authority ( Thames Water or Lewisham) responsible for the pipeline to which the connection is to be made.

69. Drainage

When directed by the Engineer or Representative, the Developer shall clean every drainage gully within the area of the Works on the existing highway. This will be through removing the grating and emptying the sump of all detritus and other matter. The sewer connection shall be cleaned using a high-pressure jetting machine. If the grating is not damaged, it shall be cleaned and re-fitted. If the grating is damaged, the grating and frame shall be replaced with a new heavy-duty grating and frame.

After completion of the works, any material that fell into the gully chamber during the works shall be removed.

All foul sewers, drains and surface water drains with watertight joints shall be tested as directed by the Engineer or representative, in sections (e.g. between manholes), before the pipes are covered by means of the air test or the water test as described in the Department for Transport Specification for Highway Works Clause 509. Before testing, the ends of the pipeline to be tested, including those of short branches, shall be plugged and sealed to the satisfaction of the Engineer. Any section not passing any of the tests shall have the defects made good and shall be re-tested.

On completion of the works, or earlier if the Engineer or representative agrees, all highway adoptable manholes and drains shall be flushed from end to end with water and left clean and free from obstruction. The removal of detritus from manholes, repairs to defects may be instructed by the Engineer as additional works where necessary. A CCTV camera inspection of the drains shall be carried out and a good quality image recorded. A copy of the recording and log of each of the pipelines shall be passed to the Engineer as part of the 'As constructed' information.

If the outfall is to an existing drain or sewer, you will have to prove its capacity and condition before Thames Water can approve the connection.

70. Excavation

Excavation shall be to the correct levels to receive the several materials specified. All surplus excavated material shall be removed to a tip provided by the Developer. Should a firm base not be encountered, the developer is to excavate below the formation to the direction of the Engineer and make good with approved material.

Where sub-soil has to be removed to reach the approved levels it shall be excavated in a manner that the formation undergoes the minimum possible disturbance. The formation for the road works shall be prepared for the full width of the carriageway and footways and the sub-grade shall wherever possible be compacted at its natural moisture content by eight passes of a smooth-wheeled roller having a mass per metre width of roll of 2.7 tonnes to 5.4 tonnes.

Where in the opinion of the Engineer or representative, the sub-grade is of poor quality he may require the removal of further material and its replacement by an approved general fill.

71. Sub base, Sub grade and Treatment of Soft Areas

It is of vital importance to keep water out of the sub-base, capping and sub-grade, during construction. It is good practice and will reduce the opportunity for foundation deterioration if the carriageway drainage is constructed and kept operational before foundations are constructed. During construction every effort should be made to protect the sub-grade by constructing and protecting foundation layers before rain can soften it. Sloping the formation to shed water could also prevent problems due to excess water.

The Engineer to be notified of soft areas below formation. Selected granular fill Type 2 shall be spread and levelled and each layer subjected to vibratory compaction by a roller (minimum 2700kg per unit width) until fill penetrates the substrata layer or until refusal.

72. Compaction of Soil and Fill Material

If the fill is a cohesive / clay soil, it must not be too wet or dry, a reasonable "rule of thumb" for cohesive (clay) soils is the moisture content range +/-2% of the Plastic Limit.

Soil fills to be compacted fully before placing next layer.

Granular fills must be well graded, with the particle size well distributed through the range of the fill material.

The Developer must consult the Specification for Highway Works to choose the compaction plant and numbers of passes / blows and ensure correct compaction plant is on site.

73. Compaction of Unbound Material

Compaction of unbound mixtures shall be carried out by a method specified in Table 8/4, Clause 802 of the Specification for Highway Works. Material of compacted thickness greater than 225 mm shall be laid in two or more layers and the minimum compacted thickness of any such layer shall be 110 mm.

74. Compaction of Bituminous Materials

Bituminous compaction will depend upon the grade of bitumen present in the mix, the temperature of the material at rolling, and the weight of the roller, i.e. the compactive effort it can exert. This will not entirely be weight related if it is a vibratory roller. On site, the Developer to ensure the correct roller and rolling takes place above the minimum rolling temperatures specified.

Maximum thickness of 40mm nominal size bituminous basecourse is 150mm, (with a big roller).

75. Filling

The order of work is to be so arranged to ensure that the excavated or filled formation shall not be exposed to weathering or damage to site traffic for a longer period than necessary. To ensure this, the Engineer, may direct that the excavated formation be left proud of the final levels and that trimming to the finished contours be carried out immediately prior to the laying of the sub-base. The formation shall be kept free from water during the progress of the works.

Unless otherwise stated general fill material shall be well graded and shall produce a well consolidated mass on compaction. The compaction in layers of not thicker than 225mm in accordance with the compaction requirements for granular materials.

When requested by the Engineer, the Developer shall provide a Certificate for imported general fill with details of the source and composition of the material and confirmation that it is free from contamination.

76. Formation

The formation is to be brought true to line, level and contour and is to be properly consolidated with approved plant.

Immediately on completion of any section of the formation it shall be sealed with bitumen emulsion sprayed at a rate of 2 m<sup>2</sup> per litre.

77. Pavement Construction

Road pavements shall be constructed as described in this specification and approved drawings with Series 700 and the appropriate clauses of the 800, 900 and 1000 of the Specification for Highway Works.

The laying of bituminous surfacings shall not be permitted if standing water is present on the substrate.

78. Granular Sub- Base

The compacted thickness shall be as shown on the drawings and it shall be laid to the correct contour.

Granular materials in a frozen condition shall not be incorporated in the Works but may be used, if acceptable, when thawed. Unbound mixtures shall not be laid on any surface which is frozen or covered with ice.

Granular materials shall be spread using a paving machine.

When requested by the Engineer, the Developer shall provide a Certificate for Type 1, and 2 materials with details of the source and composition of the material and confirmation that it is free from contamination.

79 Geogrids

In ground with a weak subgrade then a geogrids may be acceptable in lieu of a capping layer, or a combination of both. In such instances, the membrane/geotextile/geogrid shall be installed in accordance with the recommendations of the manufacturer. The layer of material on which the membrane/geotextile/geogrid is to be placed shall not have protrusions or sharp projections which are likely to damage the geotextile/membrane during installation or in service. The method of installation shall ensure that the membrane/geotextile/geogrid is in continuous contact with the surface on which it is to be placed and the geotextile/membrane shall not be stretched or bridged over hollows or humps.

Operation of construction plant directly on the installed membrane/ geotextile/ geogrid will not be permitted and its covering with fill material shall take place immediately after its laying.

80. Transport Laying and Compaction of Asphalt. Overbanding and Tack/Bond coats.

Transport, laying and compaction of asphalt in accordance with BS 594987:2007. Laying should not be carried out if standing water is present and/or any surface is frozen. Laying shall cease when the air temperature reaches 0C on a falling thermometer, except in dry conditions when the laying to be ceased at -3C on a falling thermometer. Laying may begin at -1 C on a rising thermometer.

Generally laying shall be through a paver. Hand laying only when site conditions make machine laying impracticable.

A bond coat shall be applied prior to the laying of a new course. Tack coats only to be used in constructions involving hot rolled asphalt.

The vertical faces of covers, kerbs and other projections which the asphalt is to abut shall be cleaned and painted with paving grade bitumen, before asphalt is applied. The asphalt to be tamped around and against such projections.

Rollers and compaction to be carried out by skilled and experienced personnel. Surface and binder course shall be surface finished with a smooth steel wheeled roller.

Overbanding for sealing and infilling of joints to offer high skid resistance throughout its working life.

81. Tolerances for Asphalt Laying

If requested, the Developer shall supply the Engineer a substantial straight edge 3m long. At the request of the Engineer the surfaces of the surface course and binder course shall be tested for irregularities, with a 3m straight edge placed parallel with or at right angles to the centre line of the road. The maximum allowable deviation of the surface below the straight edge shall be in accordance with Table 7 BS 594987 :2007. For machine laid +/- 6mm for surface course, binder and regulating course, and +/- 15mm for base course.

82. Mixing and Transporting Concrete

The contractor may use ready mixed concrete from an approved supplier. The mix shall comply in all respects with the specification.

Any concrete which shows signs of initial set or has been discharged from the mixer for more than one hour before depositing shall be rejected. Care must be taken during discharge from the mixer, transit and spreading to prevent segregation of the mix. The mixed materials shall be covered during transit, when directed by the Engineer, to prevent evaporation of moisture or wetting by rain.

83. Placing and Compacting Cement Bound Granular Material B Roadbase

The CBGM B shall be spread evenly and screeded.

Compacting to the Specification for Highway Works until the passes cease to move the surface, and until the surface is closed. Usually eight passes of a vibrating roller will be found to be sufficient for this purpose.

CBGM shall not be trafficked for 7 days unless the layer is compacted by both vibrating roller and/or pneumatic-tyred roller.

When tested with a 3 m straight edge the finish shall not show a departure greater than 6 mm from the true surface, the true surface being that surface complying with the lines and levels shown on the contract drawing.

84. Separation Membranes

A separation membrane shall be used between jointed reinforced concrete surface slabs or unreinforced concrete surface slabs and the sub-base. Separation membranes shall be impermeable plastic sheeting 125 microns thick laid flat without creases. Where an overlap of plastic sheets is necessary, this shall be at least 300 mm.

85. Cold-milling (Planing) of Bituminous Bound Flexible Pavement

Where milling is carried on a carriageway open to traffic, temporary ramping to ensure safe passage of vehicles shall be provided to the approval of the Engineer. Where vehicular access to any off-street premises, either commercial or residential, has been disturbed, a ramp to provide temporary access shall be provided as soon as possible: this access must be provided before the works are closed at the end of each working day, unless otherwise authorised by the Engineer.

The Contractor should note that at approaches to traffic signals there may be detector loops embedded within the carriageway surface that will be damaged during the milling process. In the event that this occurs, the Contractor must inform the Engineer as soon as possible. The Developer to arrange with Transport for London (TI-Signals Traffic Operations, Surface Transport) for the replacement of the cables upon completion of the surfacing but prior to the replacement of anti-skid surfacing (if applicable) and road markings. The Developer shall ensure that their works do not obstruct TfL, or their contractor, during cable replacement works.

Electrical cables that connect to illuminated bollards in some central refuges may lay within the existing surfacing. These may be damaged during the milling process.

After completing the planning of any area, the Developer shall programme his works so that at least one bituminous layer is laid within 2 days of planing, notwithstanding that this may require several visits of the planing machine during the programme of works.

86. Hot Rolled Asphalt Base Course and Binder Courses

Hot rolled asphalt courses shall be laid and compacted in a single course to a consolidated maximum thickness specified or to a maximum of 150 mm by means of an approved power driven mechanical paver, all in accordance with BS 594987 and Clause 904 and 905 of The Specification for Highway Works. Hand laying shall be used only where site conditions make machine laying impractical or small quantities of materials are involved.

87. Asphaltic Concrete Base and Binder Courses

Asphaltic concrete base and binder courses shall be laid and compacted in a single course to a total consolidated thickness specified or to a maximum 150 mm by means of an approved power driven mechanical paver, all in accordance with BS 594987 and Clause 906 of The Specification for Highway Works..

88. Hot Rolled Asphalt Surfacing Course

Hot rolled asphalt surfacing course shall be laid and compacted to a consolidated thickness of 40 mm by means of an approved power driven mechanical paver, all in accordance with BS 594987 and Specification for Highway Works Clause 910 and 911. 20 mm chippings as specified in accordance with BS 598-108:2005.

89. Asphaltic Concrete Surfacing Course

Surfacing course is to be laid and compacted to specified consolidated thickness of 30–40 mm by means of an approved power driven mechanical paver in accordance with BS 594987 and The Specification for Highway Works Clause 912.



90. Stone Mastic Asphalt Surfacing Course

Surfacing course is to be laid and compacted to specified consolidated thickness of 40 or 50mm by means of an approved power driven mechanical paver in accordance with BS 594987. Reference to Clause 942 and BS EN 13108-5:2006. Minimum thickness at any point 20mm for SMA 10 and 30mm for SMA 14.

**FOOTWAYS (91-95)**

91. Granular Base for Footway

The developer shall provide, spread and consolidate to a finished thickness of 100mm or 150mm a bed of granular material over the whole of the footway formation. The roller shall be to the heaviest which will compact the base without unduly disturbing the underlying sub-grade. Special care to be taken when compacting around utilities plant.

The compaction should be carried out by a method specified in Table 8/4 of The Specification for Highway Works.

92. Artificial Stone Paving

Paving shall be laid in accordance with the general requirements of Clause 1104 of the Specification for Highway Works.

Paving Slabs are generally to be laid on a 50 mm thick bed of sand grade BS 882 on a granular base. The finished surface level is to be 9 mm above the kerb level with a regular gradient towards the kerb of 1:40. All transverse joints are to be at right angles to the kerb and when the kerb is curved the transverse joints will be trimmed accordingly. The slabs are to be cut and rebated to fit all service boxes or covers and the covers are to be in their proper positions and flush with the surface of the paving.

Use of hydraulic and disc cutters are the required methods of cutting flats, blocks and pavers. Cutting by bolster is an approved method only for 50mm thick concrete flags.

93. Cement Bound Granular Material B

Cement Bound Granular Material B to the requirements of Clause 806 of the Specification for Highway Works. Where specified for footway base it is to be consolidated to a finished depth of 100 or 150mm in a single course true to levels and falls shown on the drawings.

94. Footway Asphaltic Concrete Dense Binder

AC14 dense binder 50 mm thick. To be laid and consolidated in accordance with BS 594987.

95. Footway Dense Surfacing Course

Asphaltic concrete (AC6) dense surfacing 20 mm thick ( 25mm thick where laid on 100mm or 150mm thick cement bound granular mixture B sub base). To be laid and consolidated in accordance with BS 594987.

96. Concrete Weather Conditions

Concrete shall not be placed on a frozen sub-base. In frosty weather the sub-base ahead of the concreting shall be protected against frost.

Frozen aggregates shall not be used in the concrete. The mixing or placing of concrete shall not be carried out when the atmospheric temperature is below 3 degrees C on a falling thermometer or 1 degree C on a rising thermometer.

During frosty weather the placed concrete shall be protected against damage by frost by being covered with approved material. Notwithstanding any precautions taken, the Developer shall be responsible for any damage caused by frost and the Engineer shall have the power to reject such concrete.

97. Storing of Cement

The cement shall be stored in such a position and manner that it is fully protected against rain and other atmospheric influences. The bags shall be kept off the ground, and so arranged that those which have been there for the longest time may be used first. Any bag which is torn or shows any sign that the cement has partially set shall be rejected.

98. Hand Mixing of Concrete

Where hand mixing is permitted, such as the backing and bedding of kerbs and channel, then 10 per cent extra cement shall be used. The materials shall be turned over and mixed in a dry state, and then turned over in a wet state, to mix the mass thoroughly.

99. Cement Mortar

Mortar shall not be re-used or remixed after it has become set. The consistency of all mortar shall be to the approval of the Engineer.

100. Granite Kerbs, Channels and Quadrants

Granite kerbs , channels and quadrants shall comply with BS435: 1975 with Standard Dressing A (fine picked).

Kerb face generally to be 125mm.

Kerbs or channels laid to curves of 12.0m radius or less, shall be laid using curved units of the appropriate radius. Unless otherwise agreed with the Engineer, kerbs or channels laid to curves of greater than 12.0m but less than 25.0m radius shall be laid using straight kerb units not greater than 750mm length.

Joints between kerbs, channels and quadrants shall be pointed with mortar designation (i).

Kerbs, channels and quadrants shall be laid according to the provisions of the Specification for Highway Works Series 1100.

Granite kerbs for re-use shall be selected by the Engineer.

Concrete and granite units shall be laid and bedded in accordance with BS 7533-6 on a mortar bed on a concrete pavement slab, a base or ST1 in accordance with BS 8500-2 concrete foundation. The mortar bed may be omitted if units are bedded onto a concrete slab or foundation that is still plastic. All precast units laid on a mortar bed or bedded onto plastic concrete shall be backed with a strength class ST1 concrete in accordance with BS 8500-2.

#### 101. Precast Concrete Kerbs, Channels and Quadrants and Edging

**The Council generally does not accept precast concrete kerbs, channels and quadrants for adoption.** These are only used where matching that on the existing public highway. Prior to use, approval is required from the Engineer.

Where used precast concrete kerbs, channels and quadrants to BS EN 1340 are to be laid to lines and levels shown on the drawing, bedded on and backed with 150 mm thickness of concrete class ST1. Joints are not to exceed 2 mm and are to be completely filled flush to the outer surface with 1:1 cement mortar. Radius kerbs are to be used for circular work of radii less than 18 m and for greater radii up to 21m then 600mm straights should be used. All kerbs to be laid with a 125 mm face except where false channel gradients are introduced when they shall vary between 100 mm and 160 mm.

Where accepted precast concrete kerbs to be 125mm x 255mm to be half battered.

Precast units to be laid before concrete sets. Alternatively where kerb base set then kerb to be laid on 10-40mm mortar bed with 16mm diameter dowel bars at 450mm centres between bedding and backing.

Precast concrete edging to be 20mm x 50mm half round or flat top.

102. Vehicular Crossings

Vehicular footway crossings are to be formed to the size and position shown on the drawing. Vehicular footway crossover in 200 x 100 x 80 mm concrete block paving in 45 degree herring-bone bond on 150mm thick Cement Bound Granular Mixture B and 50 mm thick fine aggregate to BS 882 grading C or M bedding as detail. For the full width of the crossover, the kerb will be ramped and set with a 25mm upstand over the channel.

Heavy duty vehicular footway crossover consisting of granular material Type 1 sub-base 150 mm thick, 60mm HRA 60/20 binder course and 40mm HRA 35/14 surface course, with 14mm pre-coated chippings as shown in detail.

103. Adjust Surface Box Covers

The developer shall adjust all covers that may be necessary to the correct finished levels of the footpath and carriageway surfaces.

104. Soft Landscaped Areas

The ground over the whole area to be cultivated shall be dug and cleared of all builders rubble, etc. to a depth of 300 mm below formation level.

Where turf is to be laid the formation is to be covered to a depth of 150 mm with good friable soil.

Where shrubs are to be planted beds shall be formed and the formation is to be covered to a depth of 500 mm with good quality fibrous loam.

On areas to be turfed best quality weed free meadow turf is to be laid to the satisfaction of the Engineer.

In shrub beds, well established shrubs shall be planted in accordance with the approved planting plan.

105. On Completion

On completion the work shall be left in a clean and tidy condition to the satisfaction of the Engineer.

## Highway Structures

Lewisham require the proposer to submit an Approval in Principle (AIP) process complying with the requirements of BD2/12. Where structural eurocodes are used additional guidance are given in IAM 124/11 Refer to

<http://www.standardsforhighways.co.uk/ha/standards/dmrb/vol1/section1/bd212.pdf>

- 1 All bridges, culverts, retaining walls, masts, columns/pillars are to be designed in accordance with the current Design Manual for Roads & Bridges and appropriate British Standards/Euro Codes [and approved by a Chartered Civil or Structural engineer].  
The Technical Approval Authority will be the London Borough of Lewisham.  
Timber shall not be used as any part of the permanent works.  
All steel bridges shall be protected by a paint system giving a minimum period of 25 years before any maintenance is required.
- 2 All warrantees, guarantees, indemnities, etc, are to be transferable to the Council
- 3 The following documents are to be supplied to the Council, where relevant, and in electronic and hard copy formats:
  - A Estimate of construction cost. Design options with reasons for effective recommendations. Calculations, indexed and clearly marked to show loads, points of application, structural modelling, other design parameters, and assumptions for the as-built structure. NB. Receipt of these is for record purposes only, and does not imply acceptance of accuracy or approval.
  - B Specification relating to as-built structure
  - C As-built drawings for all the permanent works
  - D Design Certificate, duly signed by a Chartered Civil/Structural Engineer.
  - E Design Check Certificate, duly signed by a Chartered Civil/Structural Engineer.
  - F An interpretive soils investigation report highlighting all design parameters, and engineering interpretation
  - G Name of Chartered Engineer/Consultant duly authorised to take responsibility for this project
  - H Name of Principle Contractor
  - I Names and details of contacts for site works
  - J Names of Sub-Contractors
  - K Pre-contract and construction phase Health & Safety Plans
  - L Approved Method Statements
  - M Results of all materials [e.g. concrete cubes, welds, paint systems, etc.] and components [e.g. beams, bearings, etc.] tests
  - N Manufacturers' product data sheets for components & COSHH assessments
  - O Location details of all statutory service provider's equipment, plant, ducts, cables etc. on and in vicinity of structure]
  - P Copies of all planning consents [e.g. from local authority, Environment Agency, transport undertaking]
  - Q Special requirements as to loadings, widths, materials, inspections
  - R Structure's maintenance & inspection manual [access, repair materials, component replacement programmes, etc.
  - S Photographs of the structure during demolition/modification/ construction
  - T Complete Health & Safety File [which may include requirements listed above]
  - U Approval in Principle document – final version

- V Date of practical completion
- W No attachment unrelated to the structural/safety integrity of the bridge whatsoever may be fixed howsoever to the bridge structure unless permitted by a works agreement. No such attachment shall destabilize any part of the bridge by virtue of its normal use, abuse, or consequent to neglect of its maintenance. Any attachment must be removed, upon reasonable notice served by the Council, in order for the bridge to be maintained, repaired, widened, or replaced and such removal and reinstatement, if the latter be permitted, shall be born at the attachment owner's sole cost and without compensation.

#### New Walls

- 4 All walls in excess of 1.4m in height that support the Highway or lie within either 3.7m of the Highway or 1.5 times the wall height (whichever is the least) are to be designed in accordance with current British Standards/ Euro Codes, Codes of Practice, DfT Technical Memoranda and good engineering practice and be submitted by a Chartered Civil or Structural Engineer.  
The Technical Approval Authority will be the London Borough of Lewisham.  
Timber shall not be used as any part of the permanent works.
- 5 No water shall drain through a wall, onto adoptable/adopted Public Highway.
- 6 All warranties, guarantees, indemnities, etc, to be transferable to the Council.
- 7 The following documents are to be supplied to the Council, where relevant, and in electronic and hard copy formats:
  - A Calculations, indexed and clearly marked to show loads, points of application, structural modelling, other design parameters, and assumptions. NB. Receipt of these is for record purposes only, and does not imply acceptance of accuracy or approval.
  - B Specification relating to as-built structure
  - C As-built drawings for all the permanent works
  - D Design Certificate, duly signed
  - E Design Check Certificate, duly signed
  - F Soils investigation report and engineering interpretation
  - G Name of Engineer/Consultant
  - H Name of Principle Contractor
  - I Names and details of contacts for site works
  - J Names of Sub-Contractors
  - K Pre-contract and construction phase Health & Safety Plans
  - L Approved Method Statements
  - M Results of all materials [e.g. concrete cubes, welds, paint systems, etc.] and components [e.g. beams, bearings, etc.] tests
  - N Manufacturers' product data sheets for components & COSHH assessments
  - O Location details of all statutory service provider's equipment, plant, ducts, cables etc. on and in vicinity of structure]
  - P Copies of all planning consents [e.g. from local authority, Environment Agency, transport undertaking]
  - Q Special requirements as to loadings, widths, materials, inspections
  - R Structure's maintenance & inspection manual [access, repair materials, component replacement programmes, etc.
  - S Photographs of the structure during demolition/modification/ construction

## Contact Details

Oscar Akintoye - Highways Engineer (Engineer)	0208 314 7051	<a href="mailto:oscar.akintoye@lewisham.gov.uk">oscar.akintoye@lewisham.gov.uk</a>
John Algar – Street Lighting Client Monitoring Manager	0208 394 4717	<a href="mailto:john.algar@workingwith.skanska.co.uk">john.algar@workingwith.skanska.co.uk</a> <a href="mailto:john.algar@skanska.co.uk">john.algar@skanska.co.uk</a>
Pam Bacchus – Senior Engineer (Highways)	0208 314 2215	<a href="mailto:pam.bacchus@lewisham.gov.uk">pam.bacchus@lewisham.gov.uk</a>
Stuart J Copeland, TI- Signals, Traffic Operations, Surface Transport	020 3054 2496	<a href="mailto:stuart.copeland@tfl.gov.uk">stuart.copeland@tfl.gov.uk</a>
Alexandra Crush – Policy & Development Manager		<a href="mailto:alexandra.crush@lewisham.gov.uk">alexandra.crush@lewisham.gov.uk</a>
Adam S Duff – Performance & Planning Manager, Surface Transport	020 3054 2663	<a href="mailto:adam.duff@tfl.gov.uk">adam.duff@tfl.gov.uk</a>
Jonathan Fish – Principal Parking Engineer	020 3054 2570	<a href="mailto:jonathan.fish@lewisham.gov.uk">jonathan.fish@lewisham.gov.uk</a>
Gillian Redrup– Senior Engineer (Structures)	020 8314 2589	<a href="mailto:gillian.redrup@lewisham.gov.uk">gillian.redrup@lewisham.gov.uk</a>
Julie Hassell – Principal Sponsor, Surface Transport	020 3054 1064	<a href="mailto:julie.hassell@tfl.gov.uk">julie.hassell@tfl.gov.uk</a>
Vacant– Highways Manager (Engineer)	0208 314	
Cesar Sanchez Hernandez Tfl Engineering Services- Senior Traffic Engineer	020 3054 9705	<a href="mailto:cesarsanchez@tfl.gov.uk">cesarsanchez@tfl.gov.uk</a>
Peter Moss Tree Services Officer (Arboriculturalist)	0208 314 2289	<a href="mailto:peter.moss@lewisham.gov.uk">peter.moss@lewisham.gov.uk</a>
Louise McBride – Service Group Manager Highways and Transport	0208 314 6486	<a href="mailto:louise.mcbride@lewisham.gov.uk">louise.mcbride@lewisham.gov.uk</a>
Catherine Paterson – Senior Development Officer	0208 314 2160	<a href="mailto:catherine.paterson@lewisham.gov.uk">catherine.paterson@lewisham.gov.uk</a>

## Contact Details

Eleanor Templeton- Development Officer	0208 314 2682	<a href="mailto:eleanor.templeton@lewisham.gov.uk"><u>eleanor.templeton@lewisham.gov.uk</u></a>
Geoff Tice – Asset Network Manager	0208 314 2246	<a href="mailto:geoff.tice@lewisham.gov.uk"><u>geoff.tice@lewisham.gov.uk</u></a>
Dave Wheeler - Asset Network Co-ordinator	0208 314 2218	<a href="mailto:dave.wheeler@lewisham.gov.uk"><u>dave.wheeler@lewisham.gov.uk</u></a>
Paula Young – Senior Planning Lawyer	0208 314 2218	<a href="mailto:paula.young@lewisham.gov.uk"><u>paula.young@lewisham.gov.uk</u></a>



INDEX OF SPECIFICATION AND WORKMANSHIP

<u>SUBJECT</u>	<u>PAGE</u>
Accommodation	65
Aggregates :	
Concrete	51
Artificial Stone Paving Flags	51
Asphalt	
Compaction	54,56
Tolerances for laying	70
Transporting	70
Asphaltic Concrete	55
Base	72
Binder	72
Coated Chippings	72
Surfacing Course	55,72
Base Courses	54
Bitumen Emulsion	69
Binder Courses	72
Block Paving	56,76
Bollards	52,60
Breedon Gravel	53
Bricks	57
Cement	50
Storage	62
Cement Bound Granular Material B	51,71
Cement Mortar	74
Channels	74
Chippings	76
Cold Milling	71
Compaction of soil and fill material	67
Compaction of unbound material	68
Completion of Works	66,76
Concrete : In-Situ	
Aggregates	51
Granolithic	51
Hand Mixing	74
Mixing and Transport	
Weather Conditions	74
Concrete : Precast	75
Channel Blocks	74
Edging	75
Kerbs	75
Crossovers	45, 56
Cycle Stands	52,58
Dowel Bars	75
Drainage	66
Connections	66
Cover and Frames	58

INDEX OF SPECIFICATION AND WORKMANSHIP

<u>SUBJECT</u>	<u>PAGE</u>
Ducts	56
Excavation	67
Expansion Joint	58
Filler	
Sealer	59
Feeder Pillars	59
Fencing Temporary	61
Filling	68
Flags (Paving)	51
Footway	73
Base	
Binder	
Crossovers	56
Surfacing Course	74
Formation	67
General	50
Geogrids	69
Geotextiles	69
Granite	
Kerbs, Channels and Quadrants	74
Paving	46
Setts	32
Granular Sub-Base	71
Gritting	82
Guard Railing	57
Gully	57
Gratings	57,59
Pots	57
Hot Rolled Asphalt	72
Base	72
Binder	54,72
Surfacing Course	72
Kerbs	74,75
Granite	74
Precast Concrete	75
Lamp Columns and Units	56
Lighting Equipment	59
Management of Works on the Public Highway	63
Mortar	
Cement	74
Name Plates	58

INDEX OF SPECIFICATION AND WORKMANSHIP

<u>SUBJECT</u>	<u>PAGE</u>
Noise Control	65
Overbanding	70
Paving	
Blocks	56,73
Concrete Slabs	53,56
Yorkstone	46,53
Reinforcement	
Bars	57
Mesh	57
Regulating Course	56
Road Markings	56
Sampling	50,61
Sand	50
Setting Out	65
Separation Membranes	71
Signs	57,60
Soft Landscaped Areas	76
Stone Mastic Asphalt Surfacing Course	55,73
Storage of Materials	62
Street Lighting	59
Brackets	59
Columns	59
Lanterns	59,60
Painting	59
Sub-Base	67
Sub-Grade	67
Supervision	61
Tack and Bond Coats	56,70
Testing Materials	56
Top Soil	59
Traffic Management	60
Tree Pits	59
Turf	59,76
Vehicle Crossings	76
Vibration Control	651
Water	51,65

Main Author Tom Henry Lewisham until November 2020